

Details of Warranty

Warranty period of our products is one year after shipment from our factory. However, please note that any failure or abnormality resulting from the following causes will not be covered by the warranty.

- Modification by parties other than Nikki Denso.
- Any non-standard operation that is different from rules and regulations stipulated by this catalog or our manual.
- Natural disasters.
- Connection with another maker's unit which is not approved by Nikki Denso.

Warranty of the device is limited for repairing only. Any damage caused by the fault of delivered device, or lost opportunity on the customer's side, profit loss, secondary damage, and accident will not be covered.

Cautions

- The products may be damaged if it is hit or dropped. Please handle carefully.
- Please make sure to install the safety device in case the product is used in the system that may have a serious accident or loss if the product is failed.
- Since the unexpected noise, electrostatic, or incase of abnormal failure of input power source, wiring, and parts may be occurred although we put our effort to keep the product quality, please consider the fail-safe design and the safety in the range of movement before use.
- Please read the instruction manual carefully and understand fully before use the product. Also, please pay attention to the cautions mentioned in the manual.
- In the product, strong magnets are used. Please do not stand near by the product if you have the pace maker device in the heart in order to avoid serious accident.
- Please make sure to unplug the all power supply cables before installing, checking, and maintenance of the product. Also, please make sure to take measures such as safety plug or locking the power supply cables to avoid re-inputting the power other than the operator.

※"τDISC", "τLinear", "Servo compass", and "τENGINE" are the registered brand of Nikki Denso Co., Ltd.
※The photos used in the catalog are for images only and may not be same as actual products.

 **Nikki Denso Co., Ltd.**
The Next Servo Power

Overseas Sales Dept.

Address: 1-4-2, Osaku, Sakura-shi, Chiba-ken 285-0802 Japan
E-Mail: overseas@nikkidenso.co.jp Website: <http://www.nikkidenso.co.jp>

TEL: +81-43-498-2315 / FAX: +81-43-498-4654

Head office

Address: 2-8-24, Arima, Miyamae-ku, Kawasaki-shi, Kanagawa-ken 216-0003 Japan TEL: +81-44-855-4311 / FAX: +81-44-854-7746

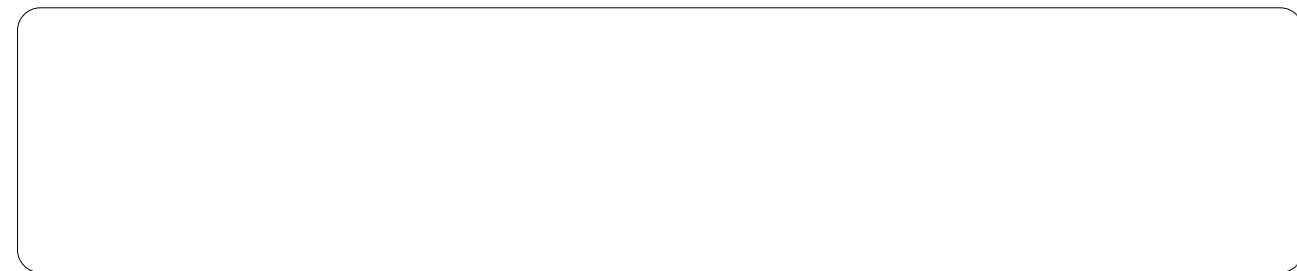

Document No. N019B201105-2000
©NIKKI Printed in Japan, gyro

The contents in this catalog is as of May 2011.
The specifications, rating, or dimensions of products in this catalog may be changed without notice for the improvement.
Although we carefully editing this catalogs, we are not responsible for any damage caused by errors and omissions.

Reprint without permission is forbidden.

 **NIKKI DENSO**
The Next Servo Power



Direct Drive Servo Motor
tau
τ DISC

D Series / HD Series / ND-c·ND Series

English

Contents



● Driver·Controller

● Encoder/Encoder cable

● Motor cable

- **DISC**
 - Characteristics P3
 - Model/Motor type P4
 - Speed stability performance characteristic graph P4
 - High response performance characteristic graph P4
- **DISC D series**
 - Motor torque characters P5
 - Specifications P6-P7
 - Assembling encoder specifications P6-P7
 - Dimensions P8~P18
- **DISC HD series**
 - Motor torque characters P19
 - Specifications P20
 - Assembling encoder specifications P20
 - Dimensions P21~P24
- **DISC ND-c·ND series**
 - Motor torque characters P25
 - Specifications P26-P27
 - Assembling encoder specifications P26-P27
 - Dimensions P28~P38
- **Motor option·standards**
 - Interpolator unit (IPU) P39
 - Encoder cable connector kit P39
 - External power supply unit P39
 - Encoder cable reference chart P40
 - Motor cable reference chart P41-P42
 - Absolute position accuracy compensation P43
 - Overseas safety standard conformity P43
 - RoHS command corresponding P43
 - Special specifications P43
- **AC Servo driver/controller VCII series**
 - Model P45
 - Index P46
 - Common specifications P47
 - Special specifications P47
 - Function specifications P48
 - DISC⇒VCII series matching chart P49-P50
 - Dimensions P51-P52
 - Factory option P52
 - Specifications and the external connection diagram P53-P54
- **AC Servo driver VPS series**
 - Model P55
 - Index P56
 - Common specifications (VCII/VPS series) P57
 - Special specifications P57
 - Function specifications P58
 - DISC⇒VPS series matching chart P59-P60
 - Dimensions P60
 - Specifications and the external connection diagram P61-P62
- **Driver option**
 - I/O connection (VCIIseries) P63-P64
 - I/O connection (VPS series) P64-P65
 - Serial communication (VCII/VPS series) P65
 - Other option (VCIIseries) P66
 - Noise prevention options (VCII/VPS series) P66
 - Regenerative resistor (Attachment) P67
 - Dynamic brake unit dimensions P68
 - DISC servo motor selection by index positioning of rotating object P69-P70
- **Torque reference chart**
 - DISC servo motor series torque reference chart P71~P72
 - The other product line-ups Nikki Denso recommends P71~P72

● DISC D series

● DISC HD series

● DISC ND-c·ND series

● DISC options

Direct drive Servo motor



D Series/HD Series/ND-c·ND Series



General motor specification	
Item	Contents
Operating ambient temperature	0°C~40°C
Operating ambient humidity	20~85%RH, No condensation
Installation location	No harmful substance such as corrosive gas, grinding fluid, metal powder, and oil are not allowed in the installation location.
Installation attitude	Horizontal, upward ※1
Cooling method	Natural cooling
Insulating classes	Class F
Dielectric strength voltage	AC 1500V, 1 min
Degree of protection	IP40(IP51) ※2
Altitude	1000m or lower
Resistance to vibration	1G(3 directions for 2 each)
Shock resistant	30G(3 directions for 3 each)
Rotation direction	Positive rotation is considered as the counter clockwise from the view of rotation surface.

※1 Please consult with our sales dept. if you intend to install other than horizontal.
 ※2 () is a protection level of ND-c series ND250/400 motor type.

Characteristics

DISC D series

DISC HD series

DISC ND-c series **DISC ND series**



Thin-High performance type

- Thinness: 44.5mm~
- Large capacity: Max torque 5800Nm
- Speed stability performance characteristic (refer to P4 chart)
- Large inertia load correspondence
- High accuracy positioning

▶▶▶ go to P5



High response type

- High response performance characteristic (refer to P4 chart)
- Suitable for high-speed index movement
- Forced air-cooling type is available to pursue higher performance.

▶▶▶ go to P19



Standard type

- Abundant product line up (22 types)
- Corresponding with one revolution absolute encoder and incremental encoder
- 110mm middle hollow type is available in the lineup.

▶▶▶ go to P25

Model/Motor type

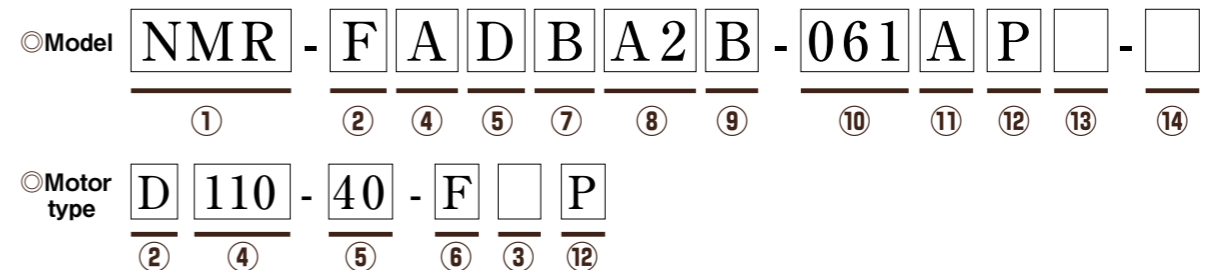

NMR·rDISC motor series	
① Model	F··D series/HD series C··ND-c series N··ND series
② Middle classification(1)	Motor type D··D series/HD series ND··ND-c series/ND series
③ Middle classification(2)	NON··D series/HD series/ND series C··ND-c series
④ Nominal diameter ※1	Flange type
	A··110(Full scale range 110 to 119mm)
	C··140(Full scale range 140 to 149mm)
	D··170/180(Full scale range 170 to 189mm)
	E··250(Full scale range 250 to 269mm)
	F··400(Full scale range 400 to 409mm)
⑤ Nominal height ※1	Flange type
	D··40(Full scale range 40 to 49mm)
	M··50/55(Full scale range 50 to 59mm)
	E··60/65(Full scale range 60 to 79mm)
	U··85(Full scale range 80 to 99mm)
	F··100(Full scale range 100 to 119mm)
⑥ Motor flange	Flange-less
	D··40(Full scale range 40 to 59mm)
	M··65/70(Full scale range 60 to 69mm)
	E··60/70/95/100(Full scale range 70 to 95mm)
	F··95/100/110(Full scale range 96 to 119mm)
	G··120/125(Full scale range 120 to 149mm)
⑦ Encoder type	D··200(Full scale range 150 to 169mm)
	H··160(Full scale range 150 to 169mm)
	I··175/185(Full scale range 170 to 199mm)
	J··200(Full scale range 200 to 219mm)
	K··225(Full scale range 220 to 225mm)
	N··225(Full scale range 225 to 249mm)
⑧ Power supply	V··630(Full scale range 630 to 639mm)
	D··40(Full scale range 40 to 49mm)
	M··50/55(Full scale range 50 to 59mm)
	E··60/65(Full scale range 60 to 79mm)
	U··85(Full scale range 80 to 99mm)
	F··100(Full scale range 100 to 119mm)
⑨ Design class	D··40(Full scale range 40 to 49mm)
	M··50/55(Full scale range 50 to 59mm)
	E··60/65(Full scale range 60 to 79mm)
	U··85(Full scale range 80 to 99mm)
	F··100(Full scale range 100 to 119mm)
	H··160(Full scale range 150 to 169mm)
⑩ Rated output	D··40(Full scale range 40 to 49mm)
	M··50/55(Full scale range 50 to 59mm)
	E··60/65(Full scale range 60 to 79mm)
	U··85(Full scale range 80 to 99mm)
	F··100(Full scale range 100 to 119mm)
	H··160(Full scale range 150 to 169mm)
⑪ Brake (With or without)	D··40(Full scale range 40 to 49mm)
	M··50/55(Full scale range 50 to 59mm)
	E··60/65(Full scale range 60 to 79mm)
	U··85(Full scale range 80 to 99mm)
	F··100(Full scale range 100 to 119mm)
	H··160(Full scale range 150 to 169mm)
⑫ Accuracy of rotating table	D··40(Full scale range 40 to 49mm)
	M··50/55(Full scale range 50 to 59mm)
	E··60/65(Full scale range 60 to 79mm)
	U··85(Full scale range 80 to 99mm)
	F··100(Full scale range 100 to 119mm)
	H··160(Full scale range 150 to 169mm)
⑬ Motor structure	D··40(Full scale range 40 to 49mm)
	M··50/55(Full scale range 50 to 59mm)
	E··60/65(Full scale range 60 to 79mm)
	U··85(Full scale range 80 to 99mm)
	F··100(Full scale range 100 to 119mm)
	H··160(Full scale range 150 to 169mm)
⑭ Symbol for special model	D··40(Full scale range 40 to 49mm)
	M··50/55(Full scale range 50 to 59mm)
	E··60/65(Full scale range 60 to 79mm)
	U··85(Full scale range 80 to 99mm)
	F··100(Full scale range 100 to 119mm)
	H··160(Full scale range 150 to 169mm)

※1 Motor type is indicated as figure. ※Actual dimensions are different from nominal. Please refer to the dimensions.

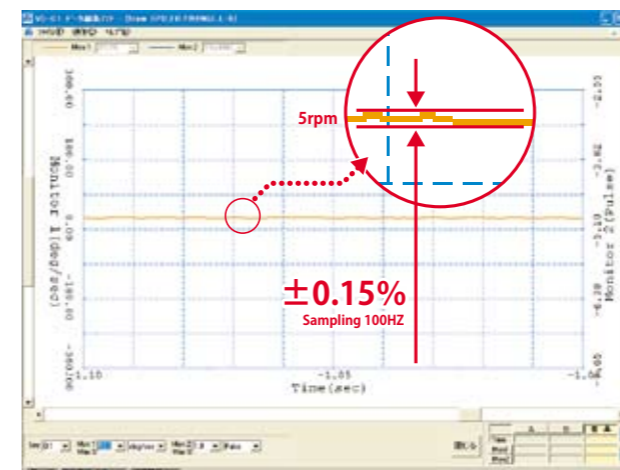

Speed stability performance characteristic
 The waveform of motor movement at 5rpm (Momentary speed variation 0.15%).
 Sampling frequency 100Hz

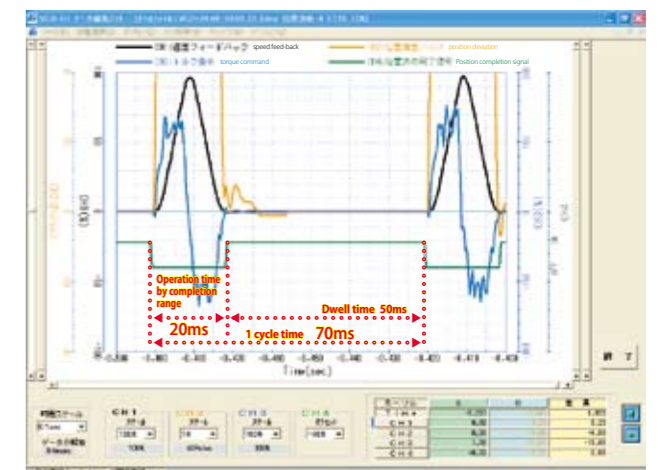

High response performance characteristic
 The waveform of 22.5deg positioning movement 857shot/min

Thin· High performance type



● TDISC D series Motor torque characters

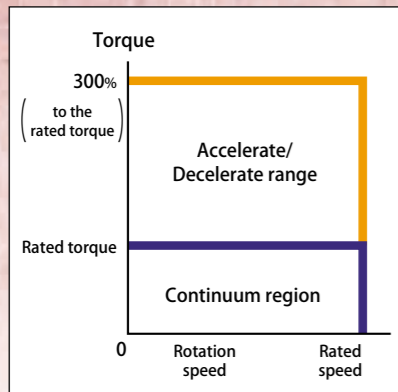

■ D110-40-F/L D110-60-F/L
D170-40-F/L D170-100-F/L
D250-40-F/L D250-100-F/L

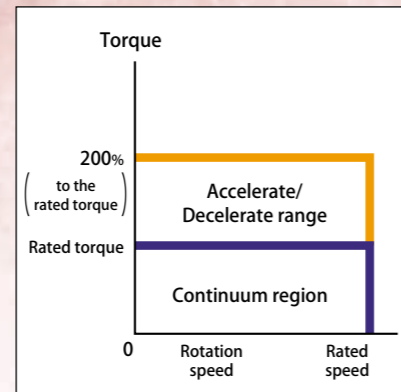

■ D400-40-F/L D400-100-F/L
D400-175-L D630-125-L
D630-175-L D630-225-L

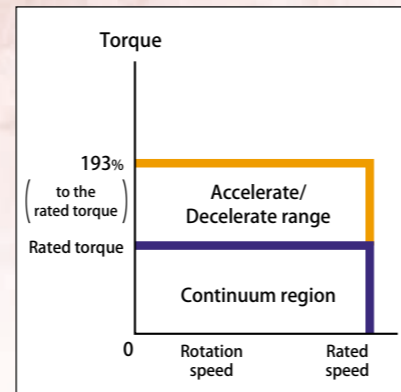

■ D630-470-F

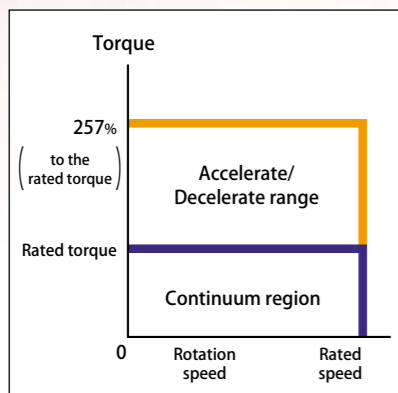

■ D400-275-L (High rigidity type)

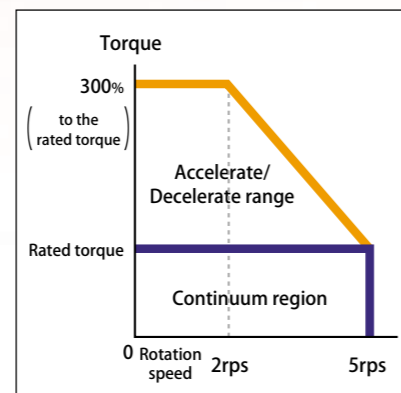

■ When operating D110-40-F/L at AC100V.
When operating D110-60-F/L at AC100V.

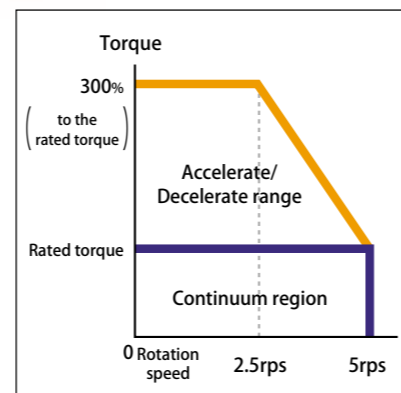

■ When operating D170-40-F/L at AC100V.

● TDISC D series Specifications

Motor type		D110-40-F	D110-40-L	D110-60-F	D110-60-L
Frang type		FADBA2C-061A	FPDBA2B-061A	FAEBA2C-121A	FPEBA2B-121A
Model	NMR-				
External	mm(φ)	110	110	110	110
Height	mm	47	55	67	75
Rated torque	Nm	2	2	4	4
Max. torque	Nm	6	6	12	12
Rated output	W	63	63	126	126
Rated current	A	2.0	2.0	2.4	2.4
Absolute position accuracy ^{※1}	sec.	±15(Option)			
Allowable moment load ^{※2}	Nm	6.1	6.1	6.1	6.1
Allowable axial load ^{※2}	kN	1.1	1.1	1.1	1.1
Radial run out (No load)	μm	20(Standard)/10(Option)			
Axial run out (No load)	μm	20(Standard)/10(Option)			
Rotor inertia	kg·m ²	0.0003	0.0003	0.0005	0.0005
Mass	kg	1.8	2.0	3.1	3.3
Magnetic pole detection method		Automatic			

Motor type		D170-40-F	D170-40-L	D170-100-F	D170-100-L
Frang type		FDDBA2D-201A	FSDBA2C-201A	FDFBA2C-701A	FSFBA2C-701A
Model	NMR-				
External	mm(φ)	177.5	177.8	177.8	177.8
Height	mm	44.5	57	104.5	115.5
Rated torque	Nm	7.5	7.5	22.5	22.5
Max. torque	Nm	22.5	22.5	67	67
Rated output	W	235	235	700	700
Rated current	A	2.1	2.1	4.8	4.8
Absolute position accuracy ^{※1}	sec.	±15(Option)			
Allowable moment load ^{※2}	Nm	49.2	49.2	89.9	89.9
Allowable axial load ^{※2}	kN	3.2	3.2	6.9	6.9
Radial run out (No load)	μm	20(Standard)/10(Option)			
Axial run out (No load)	μm	20(Standard)/10(Option)			
Rotor inertia	kg·m ²	0.002	0.002	0.009	0.009
Mass	kg	5.5	5.5	13	13
Magnetic pole detection method		Hall sensor			

Motor type		D250-40-F	D250-40-L	D250-100-F	D250-100-L
Frang type		FEDBA2C-401A	FTDBA2C-401A	FEFBA2C-122A	FTFBA2C-122A
Model	NMR-				
External	mm(φ)	254	254	254	254
Height	mm	44.5	57	104.5	115.5
Rated torque	Nm	20.7	20.7	62	62
Max. torque	Nm	60(51.75) ^{※3}	60(51.75) ^{※3}	186	186
Rated output	W	400	400	1200	1200
Rated current	A	3.4	3.4	8.0	8.0
Absolute position accuracy ^{※1}	sec.	±15(Option)			
Allowable moment load ^{※2}	Nm	140.4	140.4	337.4	337.4
Allowable axial load ^{※2}	kN	5.4	5.4	13.3	13.3
Radial run out (No load)	μm	25(Standard)/10(Option)			
Axial run out (No load)	μm	25(Standard)/10(Option)			
Rotor inertia	kg·m ²	0.017	0.017	0.047	0.047
Mass	kg	9.5	10	23	23
Magnetic pole detection method		Hall sensor			

※In order to maintain accuracy and prevent uneven wear by lack of bearing grease, please rotate the output axis for 90 deg or more in certain period.

※1 The value is only when the absolute position compensation option is used. Refer to P43 [Absolute position compensation] for details.

※2 Life of bearing and run out depend on a load.

※3 The value of () is when VPS series is used.

● Assembling encoder specifications

Motor type	Detecting pulse (ppr)	Electrical resolution (sec)	Rated speed (rps)	Encoder type	Interpolator ^{※1}	Model ^{※2}	External connector diagram No.		
							VCI series	VPS series	
D110	720,000	1.800	5.0	Incremental	Built-in	NSR-REMP1*1-10	①-1→P33 references	②-1→P61 references	
	1,440,000	0.900	5.0			NSR-REMP1*1-10	①-1→P33 references	②-1→P61 references	
	3,686,400	0.352	5.0			Separated	NSR-RHSP2*1-10	②-2→P54 references	③-2→P62 references
D170	400,000	3.240	5.0	Incremental	Built-in	NSR-REK1*1-10	①-1→P33 references	②-1→P61 references	
	1,000,000	1.296	5.0			Built-in	NSR-RELH1*1-10	①-1→P33 references	②-1→P61 references
	2,000,000	0.648	5.0			Built-in	NSR-REMH1*1-10	①-1→P33 references	②-1→P61 references
	4,000,000	0.324	2.5			Built-in	NSR-RENH1*1-10	①-1→P33 references	②-1→P61 references
D250	10,240,000	0.127	5.0	Incremental	Separated	NSR-RHSH2*1-10	②-2→P54 references	③-2→P62 references	
	900,000	1.440	3.0			Built-in	NSR-RELK1*1-10	①-1→P33 references	②-1→P61 references
	1,800,000	0.720	3.0			Built-in	NSR-REMK1*1-10	①-1→P33 references	②-1→P61 references
	3,600,000	0.360	3.0			Built-in	NSR-REML1*1-10	①-1→P33 references	②-1→P61 references
	7,200,000	0.180	1.5			Built-in	NSR-RENL1*1-10	①-1→P33 references	②-1→P61 references
	9,216,000	0.141	3.0			Separated	NSR-RHSH2*1-10	②-2→P54 references	③-2→P62 references
	18,432,000	0.071	3.0			Separated	NSR-RHSL2*1-10	②-2→P54 references	③-2→P62 references

※1 If the external type interpolator is selected, P39 interpolator unit (IPU) is installed separately.

In such case, the combination of encoder cable is P40 ②-B-1 ③-B-2.

※2 * mark refers to the design order (Non-marking or start from A~).

TDISC D series Specifications

Motor type		D400-40-F	D400-40-L	D400-100-F	D400-100-L
Frang type		FFDBA2C-801A	FUDBA2C-801A	FFFBA2C-252A	FUFBA2C-252A
Model	NMR-				
External	mm(φ)	406.4	406.4	406.4	406.4
Height	mm	48.5	57	104.5	115.5
Rated torque	N·m	67	67	200	200
Max. torque	N·m	134	134	400	400
Rated output	W	800	800	2500	2500
Rated current	A	6.3	6.3	14.3	14.3
Absolute position accuracy ^{#1}	sec.	±15(Option)			
Allowable moment load ^{#2}	N·m	579.8	579.8	1805.5	1805.5
Allowable axial load ^{#2}	kN	15.5	15.5	44.6	44.6
Radial run out (No load)	μm	30(Standard)/10(Option)			
Axial run out (No load)	μm	30(Standard)/10(Option)			
Rotor inertia	kg·m ²	0.147	0.147	0.303	0.303
Mass	kg	28	27	61	61
Magnetic pole detection method		Hall sensor			

Motor type		D400-175-L(0.66rps specification)	D400-175-L(1.5rps specification)	D400-275-L(High rigidity type)
Frang type		FUIBA2D-212AZ	FUIBA2D-472AZ	FUV*A2A-662A ^{#3}
Model	NMR-			
External	mm(φ)	406	406	455
Height	mm	186	186	275
Rated torque	N·m	500	500	700
Max. torque	N·m	1000	1000	1800
Rated output	W	2100	4700	6600
Rated current	A	19.6	29.7	48.1
Absolute position accuracy ^{#1}	sec.	±15(Option)		
Allowable moment load ^{#2}	N·m	1805.5	1805.5	3000
Allowable axial load ^{#2}	kN	44.6	44.6	50
Radial run out (No load)	μm	30(Standard)/10(Option)		
Axial run out (No load)	μm	30(Standard)/10(Option)		
Rotor inertia	kg·m ²	0.61	0.61	0.94
Mass	kg	110	111.3	195
Magnetic pole detection method		Hall sensor		

Motor type		D630-125-L	D630-175-L	D630-225-L	D630-470-F
Frang type		FVGBA2C-322A	FVIBA2C-672A	FVKBA2B-872A	FGPHA2A-133AGZ
Model	NMR-				
External	mm(φ)	630	630	690	660
Height	mm	125	175	225	470
Rated torque	N·m	500	1000	1500	3000 ^{#4}
Max. torque	N·m	1000	2000	3000	5800 ^{#4}
Rated output	W	3150	6700	8700	12600 ^{#4}
Rated current	A	25.0	47.7	47.1	76.0 ^{#4}
Absolute position accuracy ^{#1}	sec.	±15(Option)			
Allowable moment load ^{#2}	N·m	3000	5000	6000	7000
Allowable axial load ^{#2}	kN	50	80	100	70
Radial run out (No load)	μm	40(Standard)/10(Option)			
Axial run out (No load)	μm	40(Standard)/10(Option)			
Rotor inertia	kg·m ²	4.1	5	6.4	12.1
Mass	kg	260	330	430	815
Magnetic pole detection method		Hall sensor			Position detection

*In order to maintain accuracy and prevent uneven wear by lack of bearing grease, please rotate the output axis for 90 deg or more in certain period.

*1 The value is only when the absolute position compensation option is used. Refer to P43 [Absolute position compensation] for details.

*2 Life of bearing and run out depend on a load.

*3 Type in () depends on encoder type.

G:Encoder type Incremental (Separated interpolator unit type)

H:Encoder type Absolute (Separated interpolator unit type)

*4 The value is when air cooling fan is used.

Please refer to the right side figure for power supply specification of cooling fan.

■D630-470-F type power supply specification of cooling fan

Power Supply	Single phase AC200V	0.92A(50Hz)
Connection	Single phase AC200V	0.72A(60Hz)
	Connecting to the terminal block of motor body (M3 screw)	

Assembling encoder specifications

Motor type	Detecting pulse (ppr)	Electrical resolution (sec)	Rated speed (rps)	Encoder type ^{#1}	Interpolator ^{#2}	Model ^{#3}	External connector diagram No.	
							VCI series	VPS series
D400-40/100	900,000	1.440	2.0	Incremental	Built-in	NSR-RELK1*-10	①-1→P53 references	②-1→P61 references
	1,800,000	0.720	2.0			NSR-REMK1*-10		
	3,600,000	0.360	2.0			NSR-REML1*-10		
	7,200,000	0.180	1.5			NSR-RENL1*-10		
	9,216,000	0.141	2.0			NSR-RHSL2*-10		
	18,432,000	0.071	2.0			NSR-RHSL2*-10		
D400-175	900,000	1.440	0.66/1.5	Incremental	Built-in	NSR-RELK1*-10	①-1→P53 references	-
	1,800,000	0.720	0.66/1.5			NSR-REMK1*-10		
	3,600,000	0.360	0.66/1.5			NSR-REML1*-10		
	7,200,000	0.180	0.66/1.5			NSR-RENL1*-10		
	9,216,000	0.141	0.66/1.5			NSR-RHSL2*-10		
	18,432,000	0.071	0.66/1.5			NSR-RHSL2*-10		
D400-275 (High rigidity)	6,815,744	0.1902	1.5	Absolute	Separated	NSR-RPST2*-05	①-2→P54 references	-
	7,168,000	0.1809	1.5			NSR-RQSZ2*-05		
D630-125/175/225	1,800,000	0.720	1.0	Incremental	Built-in	NSR-RJLR1*-10	①-1→P53 references	-
	3,600,000	0.360	1.0			NSR-RJMR1*-10		
	7,200,000	0.180	1.0			NSR-RJNR1*-10		
	18,432,000	0.071	1.0			NSR-RHSR2*-10		
D630-470	12,582,912	0.10	0.67	Absolute	Separated	NSR-RPSNAPAA2*-10	①-2→P54 references	-

*1 Absolute encoder is one resolution absolute value.

*2 If the external type interpolator is selected, P39 interpolator unit (IPU) is installed separately.

In such case, the combination of encoder cable is P40 ①-B-1 ②-B-2.

*3 * mark refers to the design order (Non-marking or start from A~).

TDISC D series dimensions

D110-40-F NMR-FADBA2C-061A

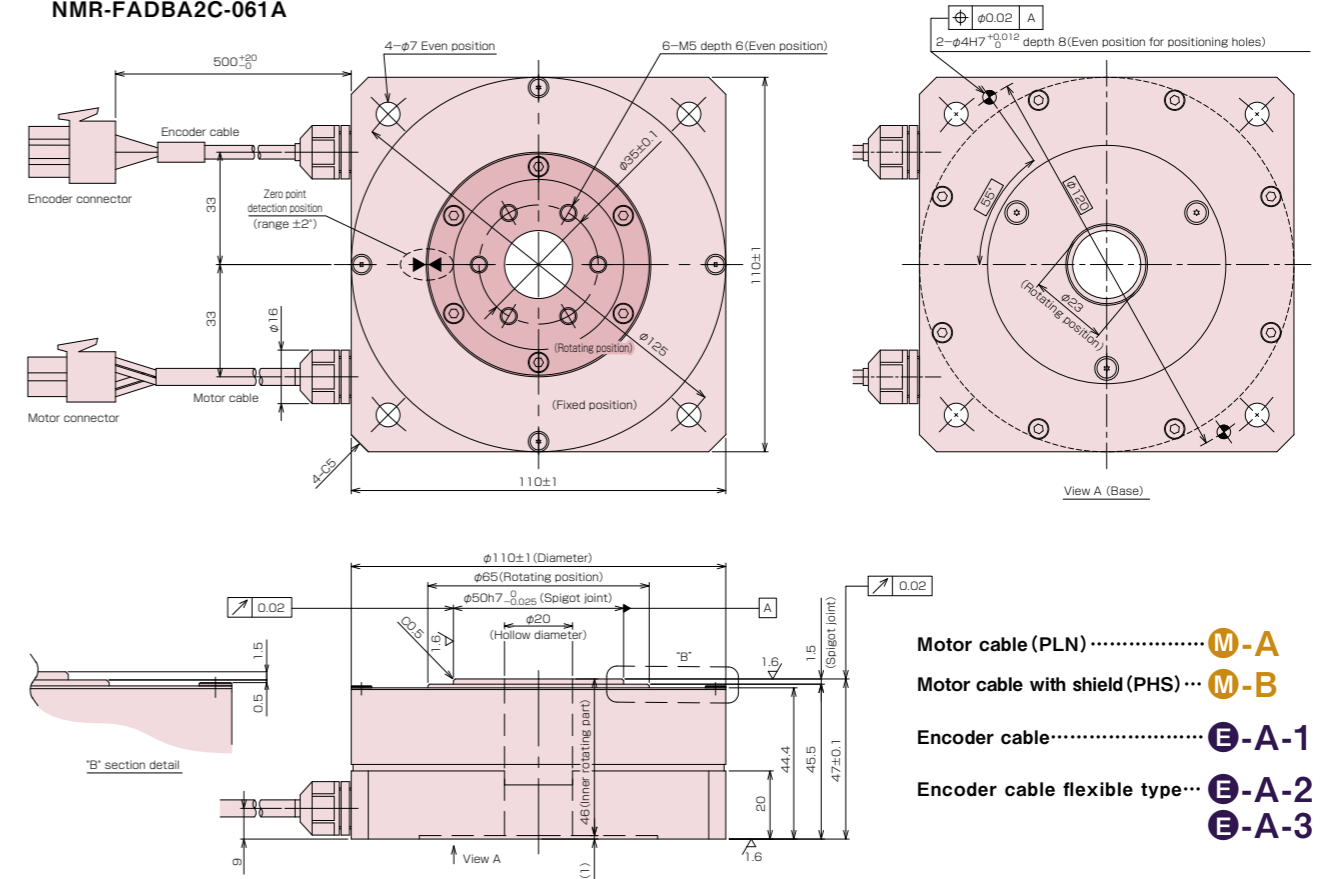

D110-40-L NMR-FPDBA2B-061A

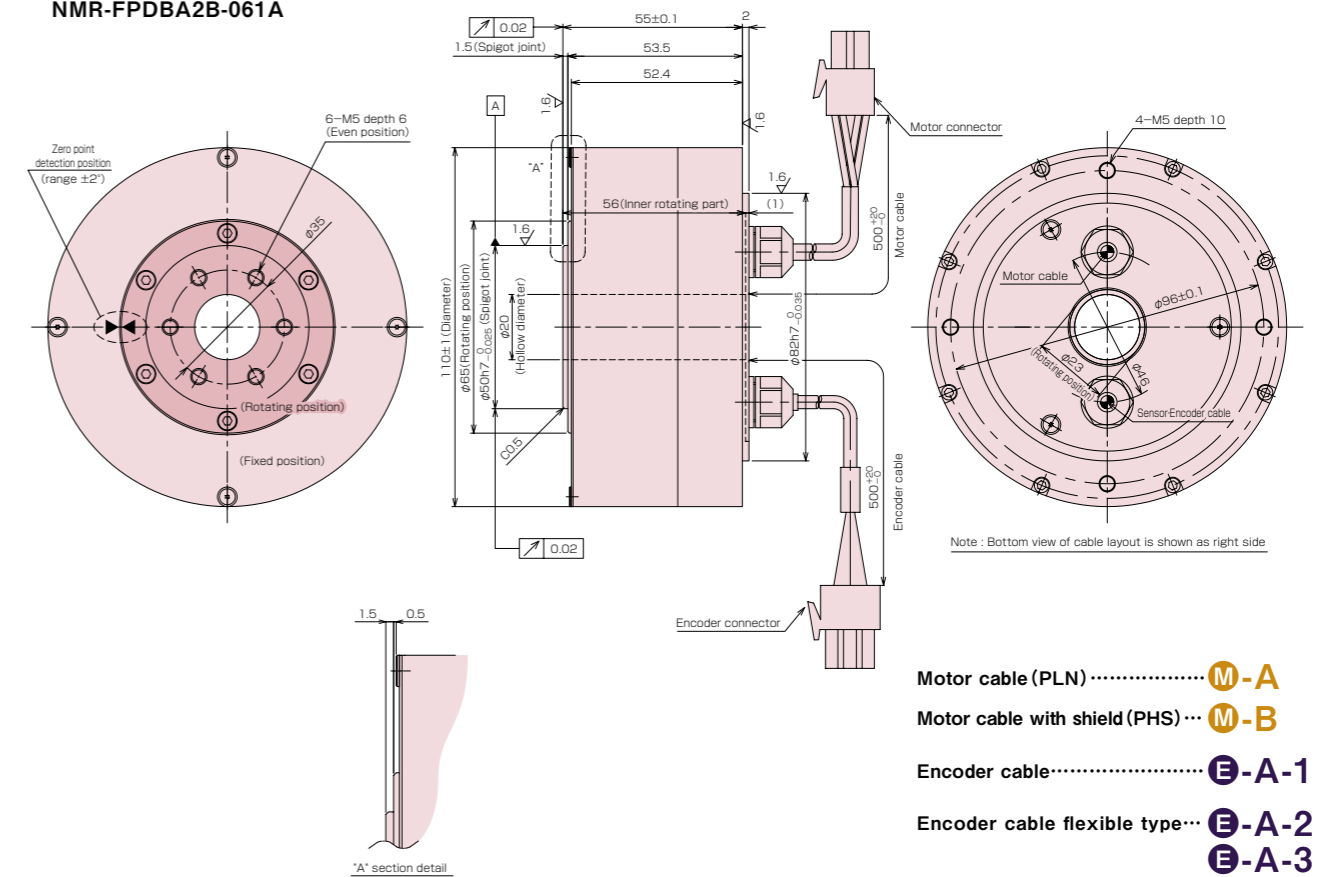

TDISC D series dimensions

D110-60-F
NMR-FAEBA2C-121A

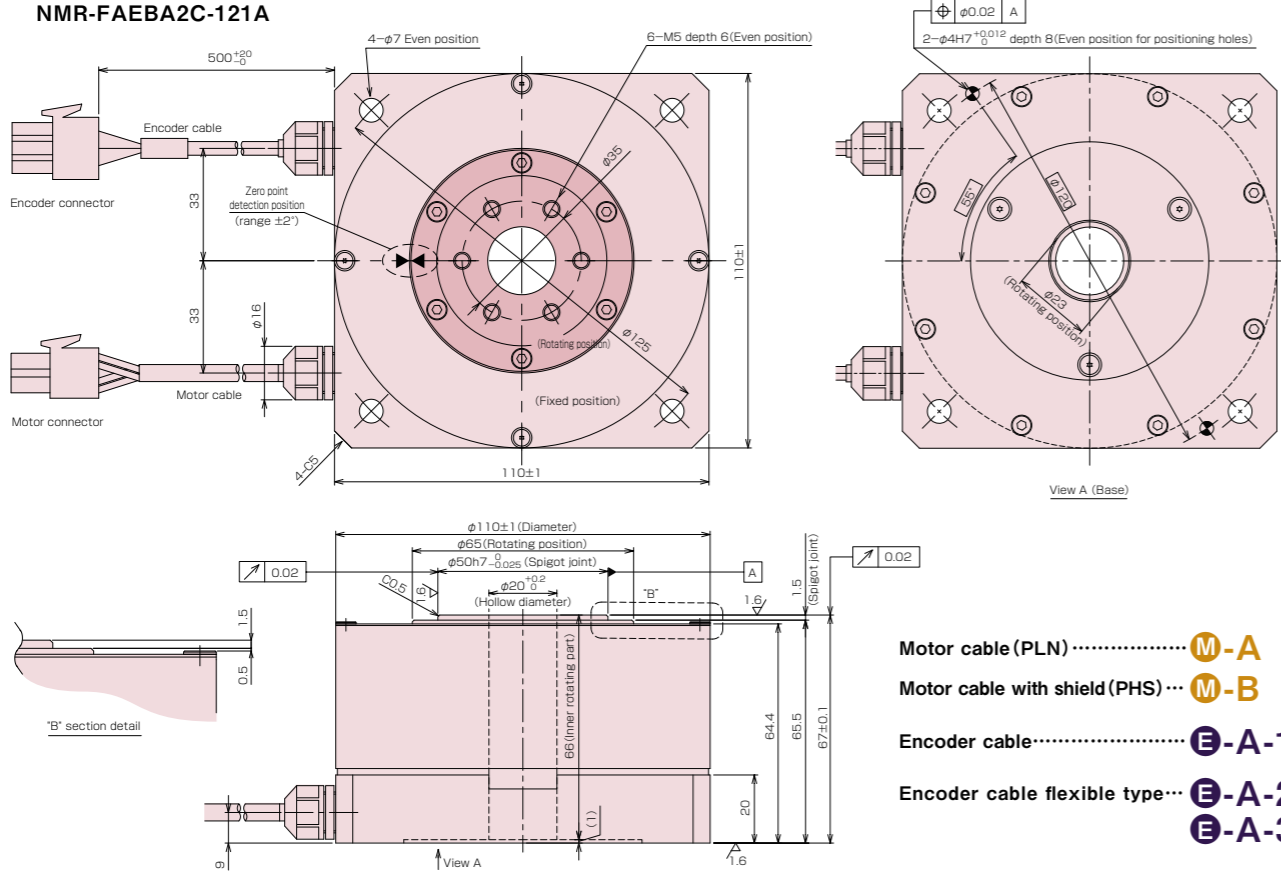

TDISC D series dimensions

D170-40-F
NMR-FDDBA2D-201A

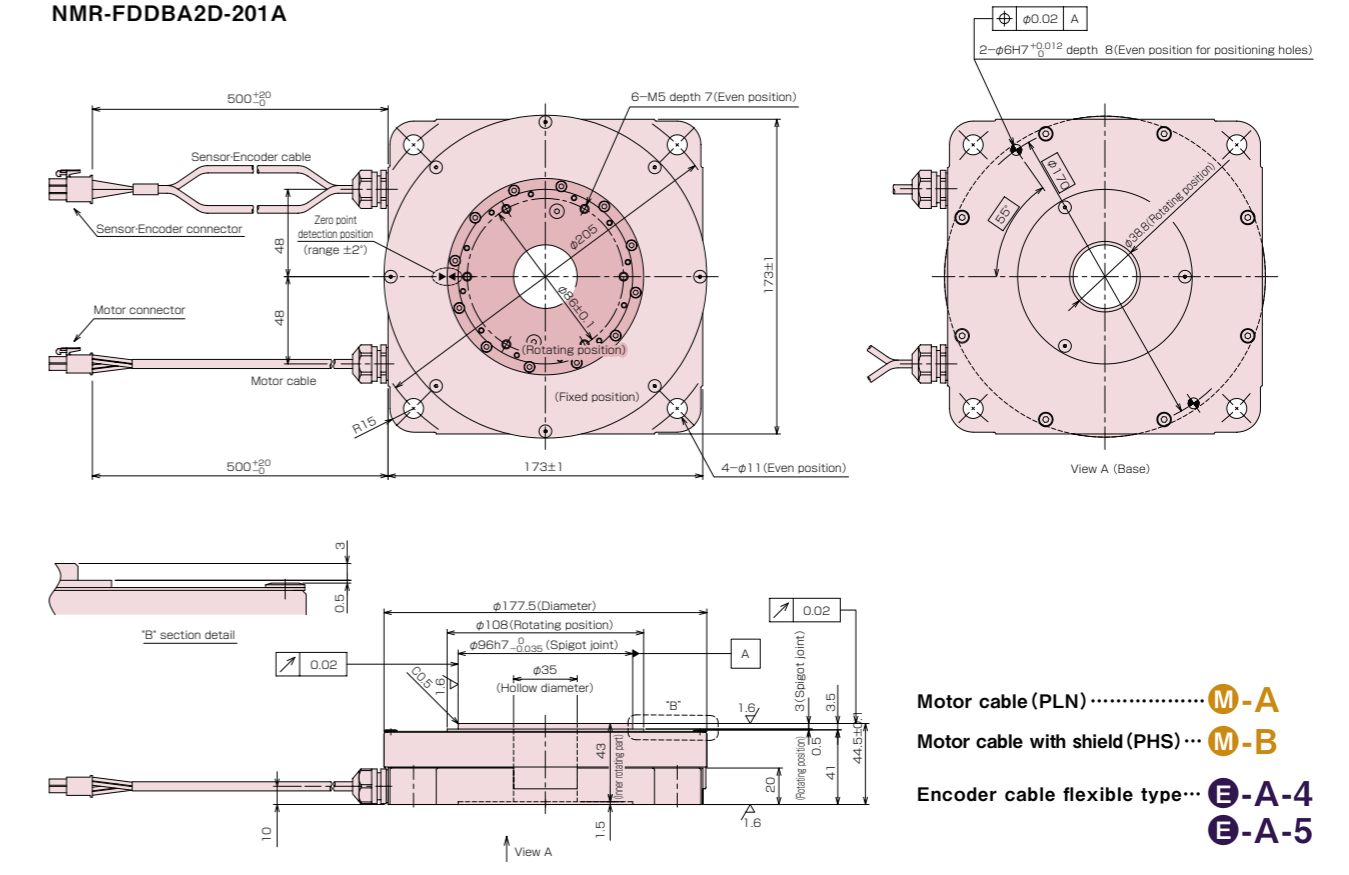

D110-60-L
NMR-FPEBA2B-121A

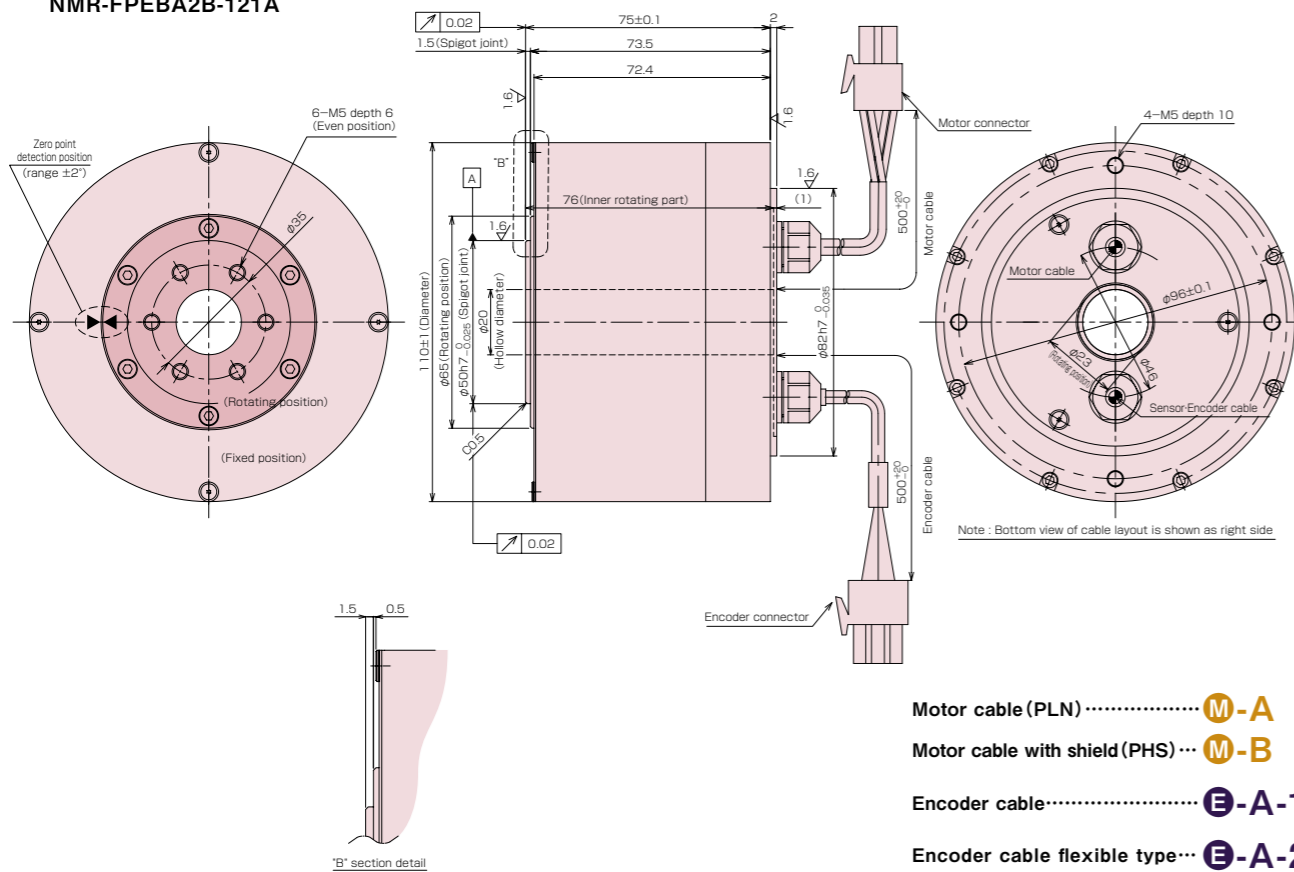

D170-40-L
NMR-FSDBA2C-201A

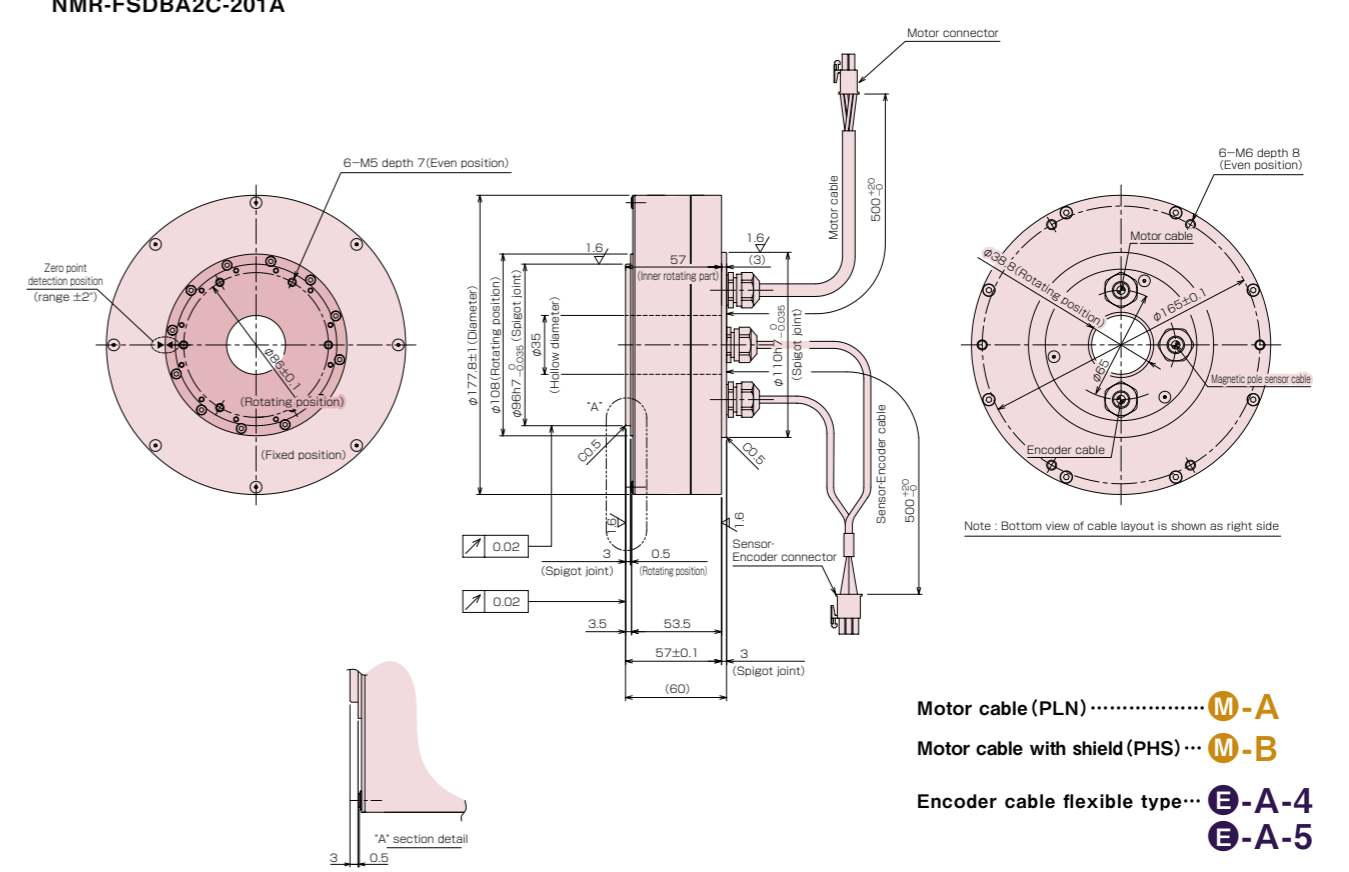

TDISC D series dimensions

D170-100-F
NMR-FDFBA2C-701A

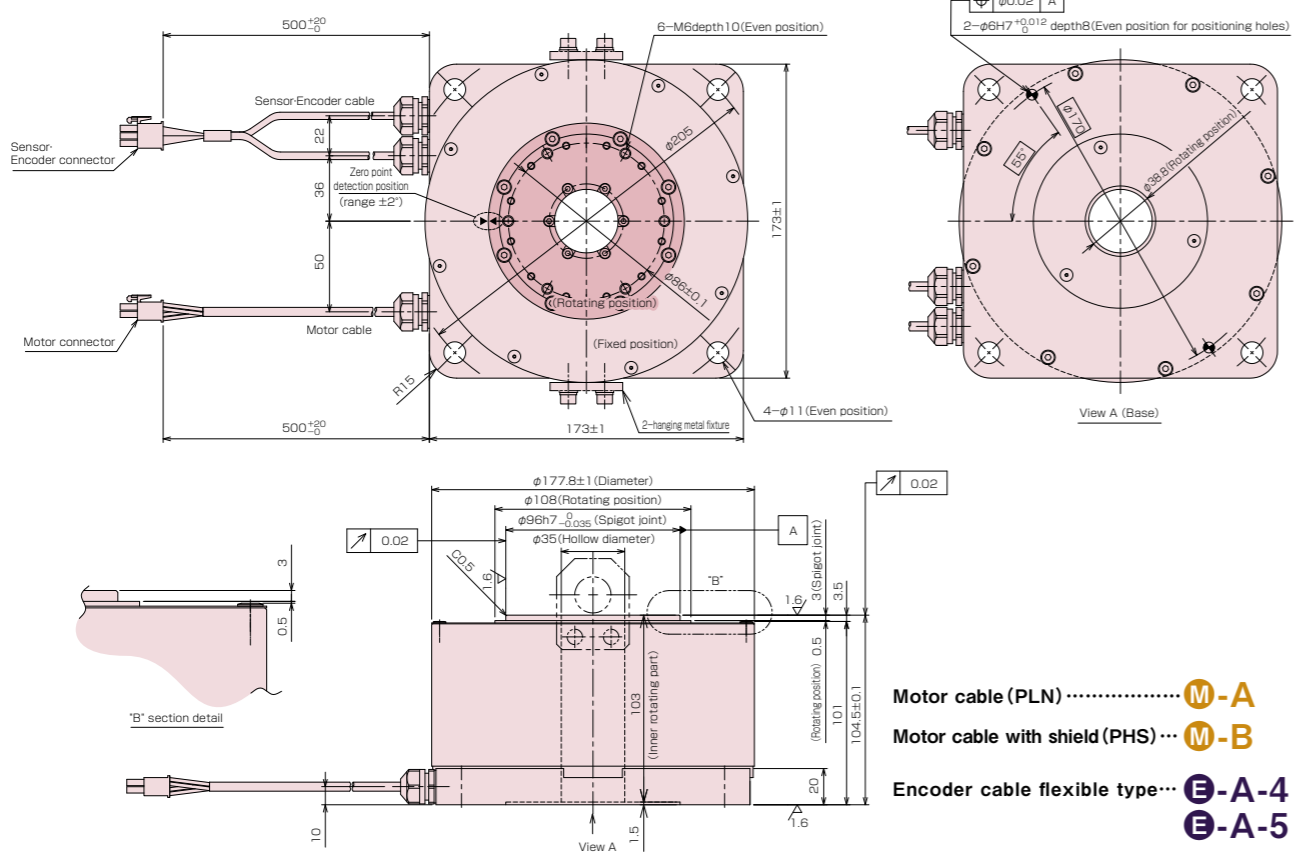

TDISC D series dimensions

D250-40-F
NMR-FEDBA2C-401A

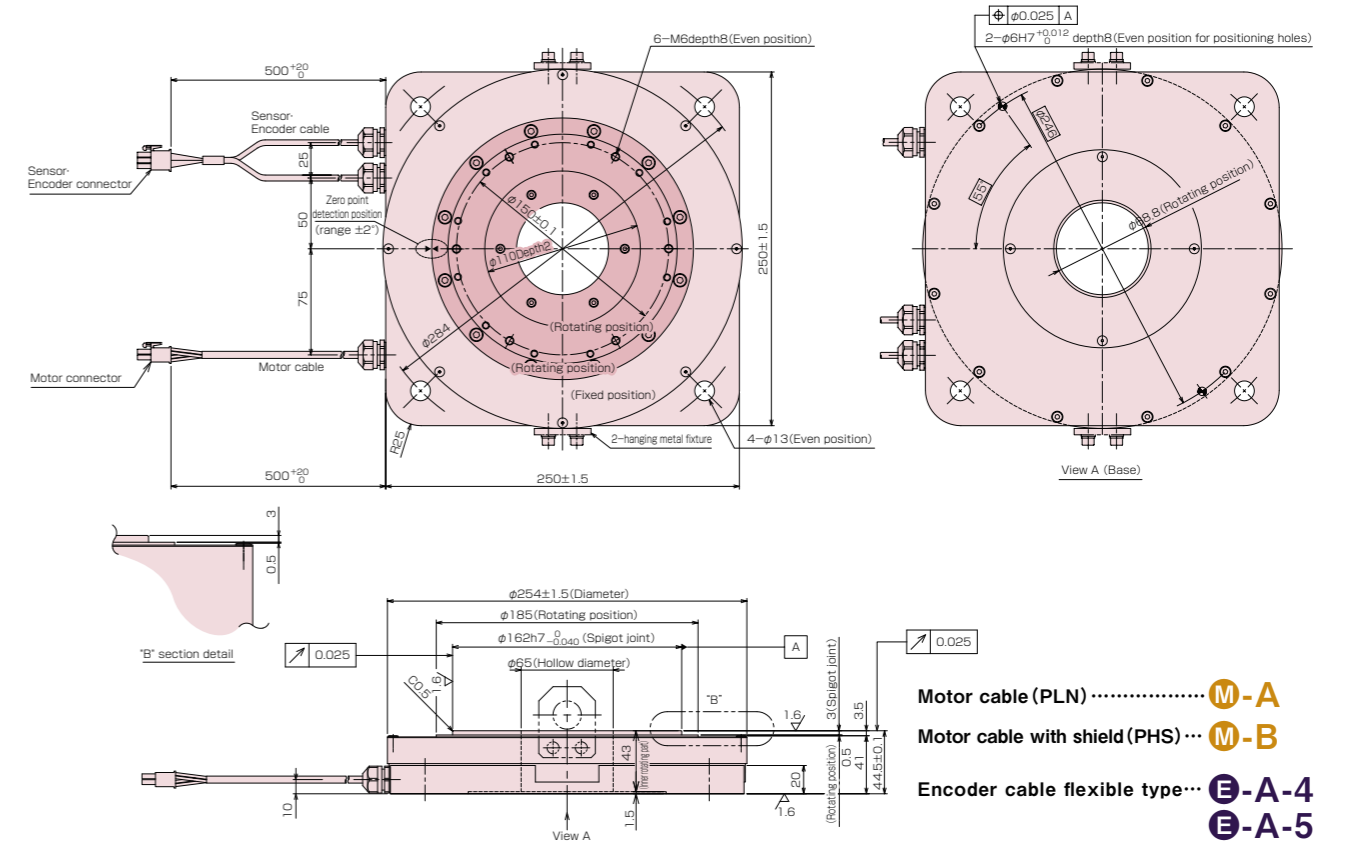

D170-100-L
NMR-FSFBA2C-701A

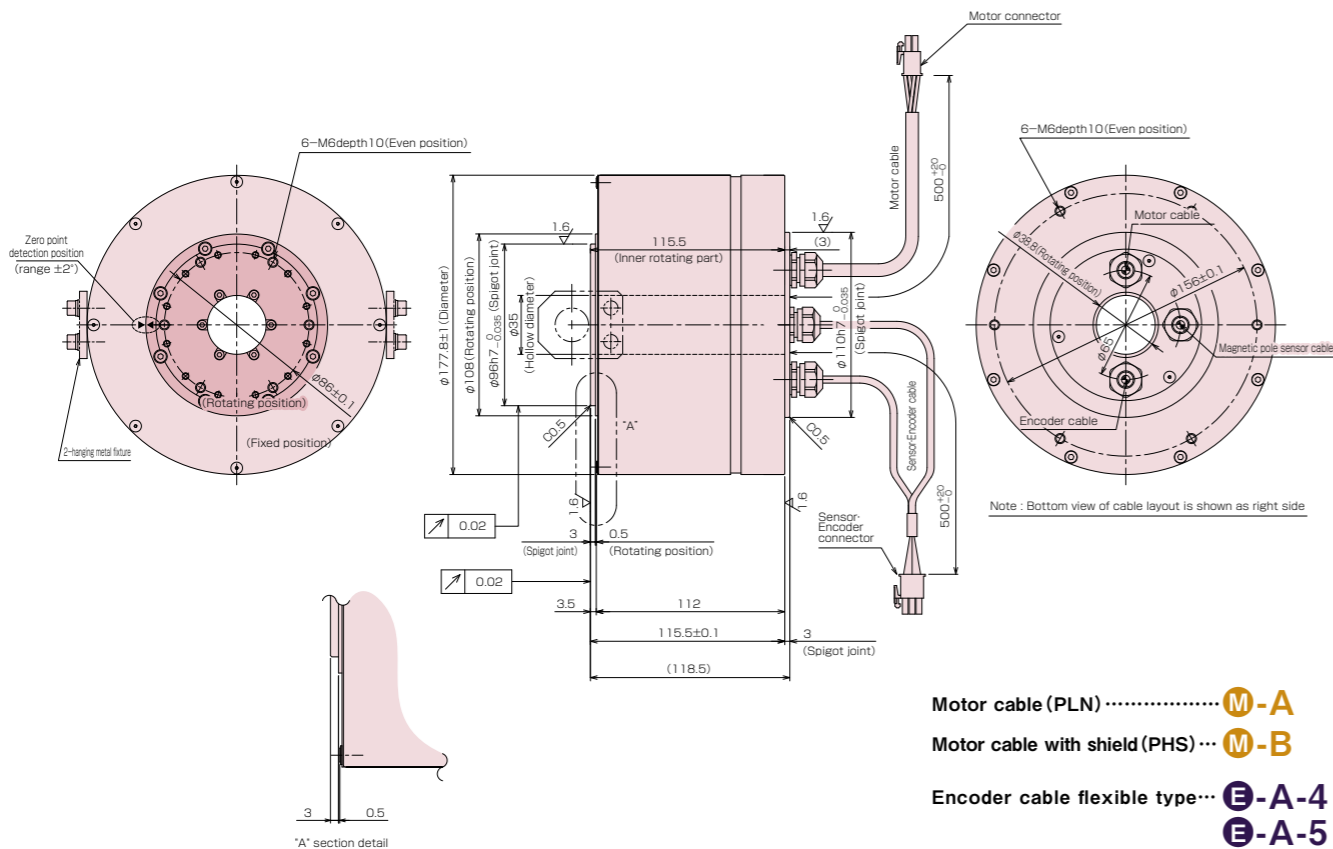

D250-40-L
NMR-FTDBA2C-401A

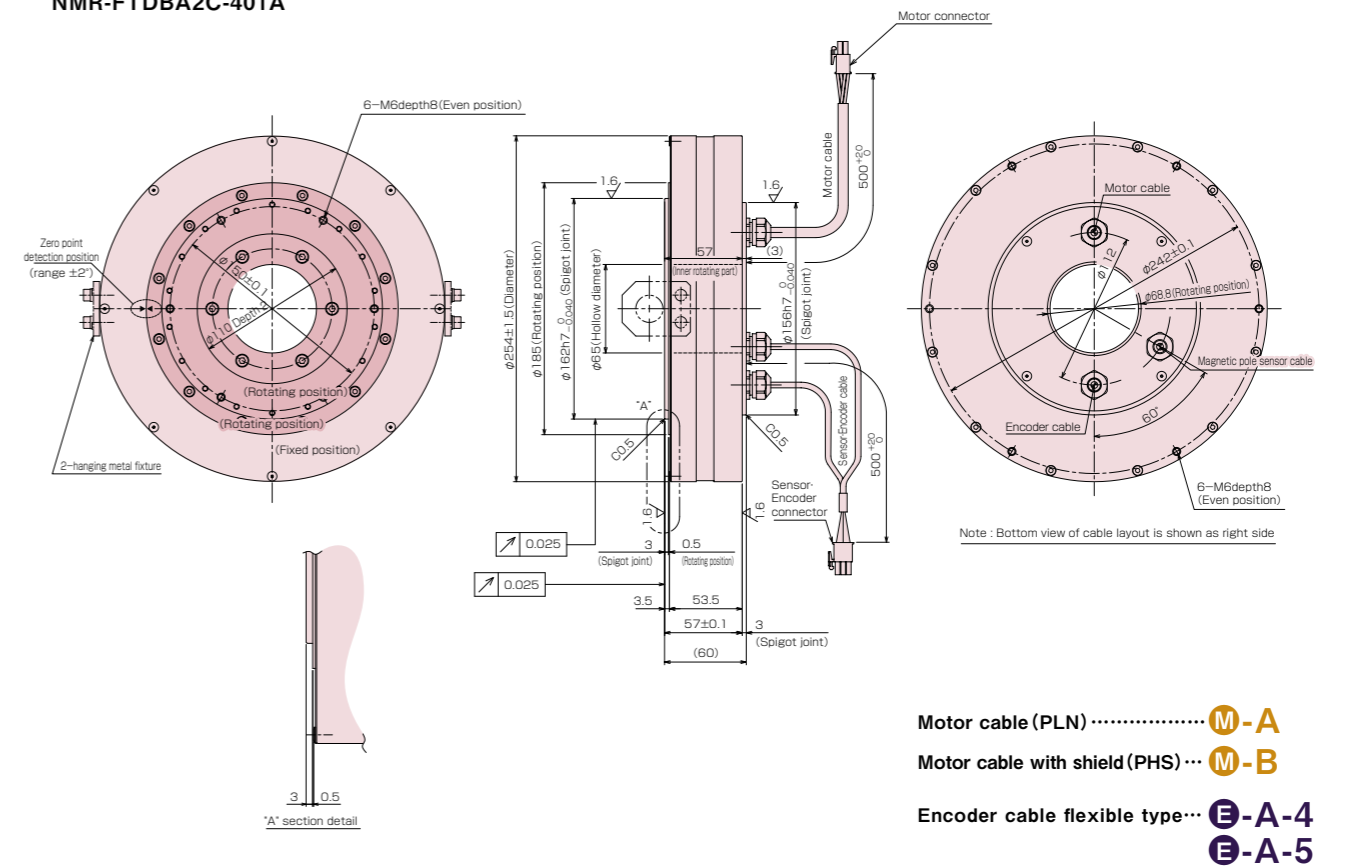

● TDISC D series dimensions

○ D250-100-F
NMR-FEFA2C-122A

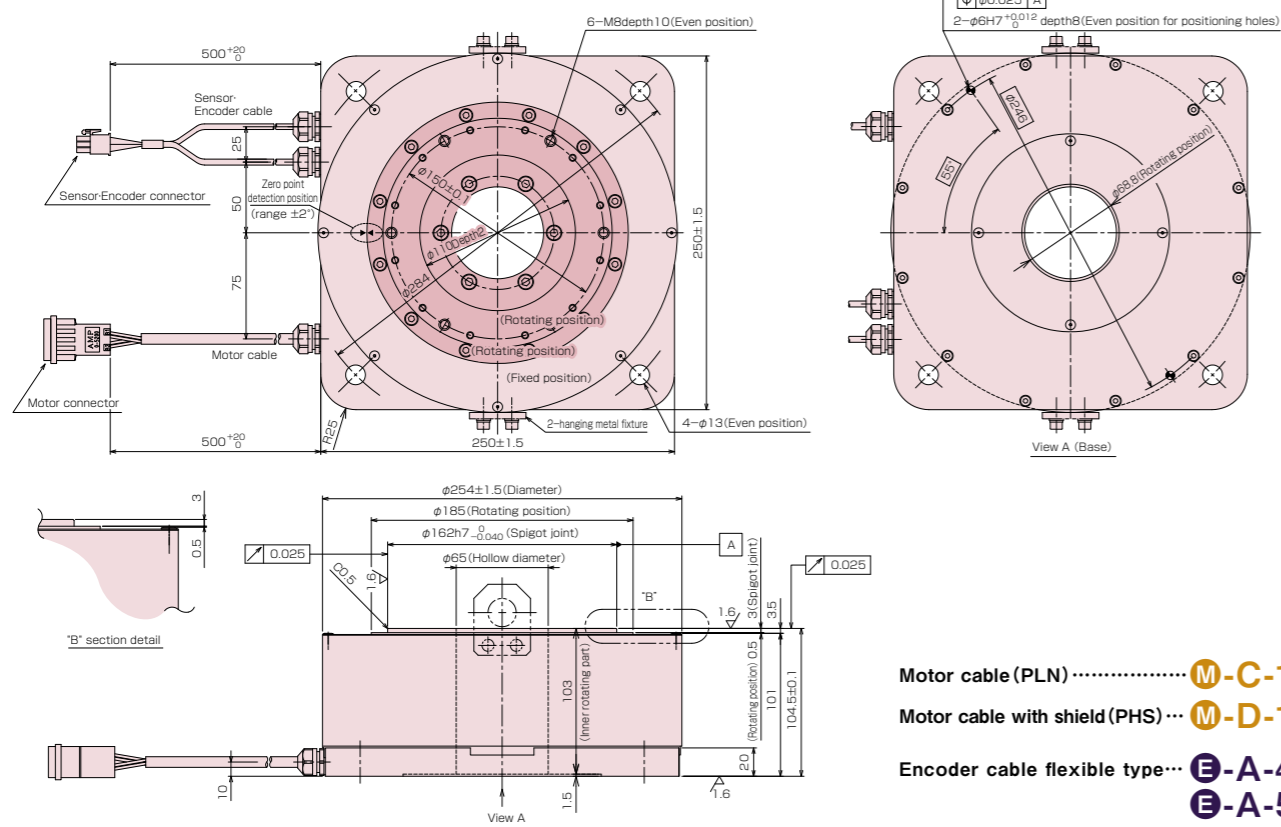

○ D250-100-L
NMR-FTFA2C-122A

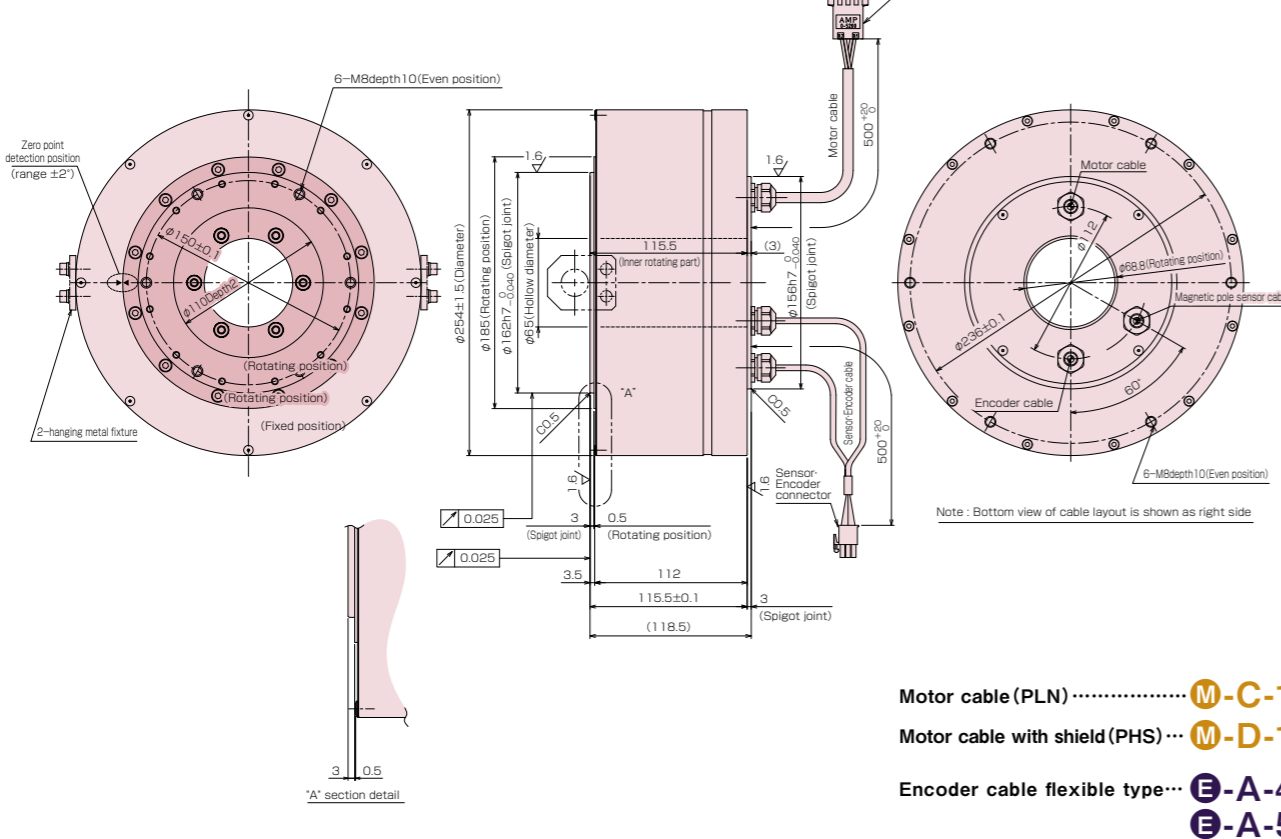

● TDISC D series dimensions

○ D400-40-F
NMR-FFDBA2C-801A

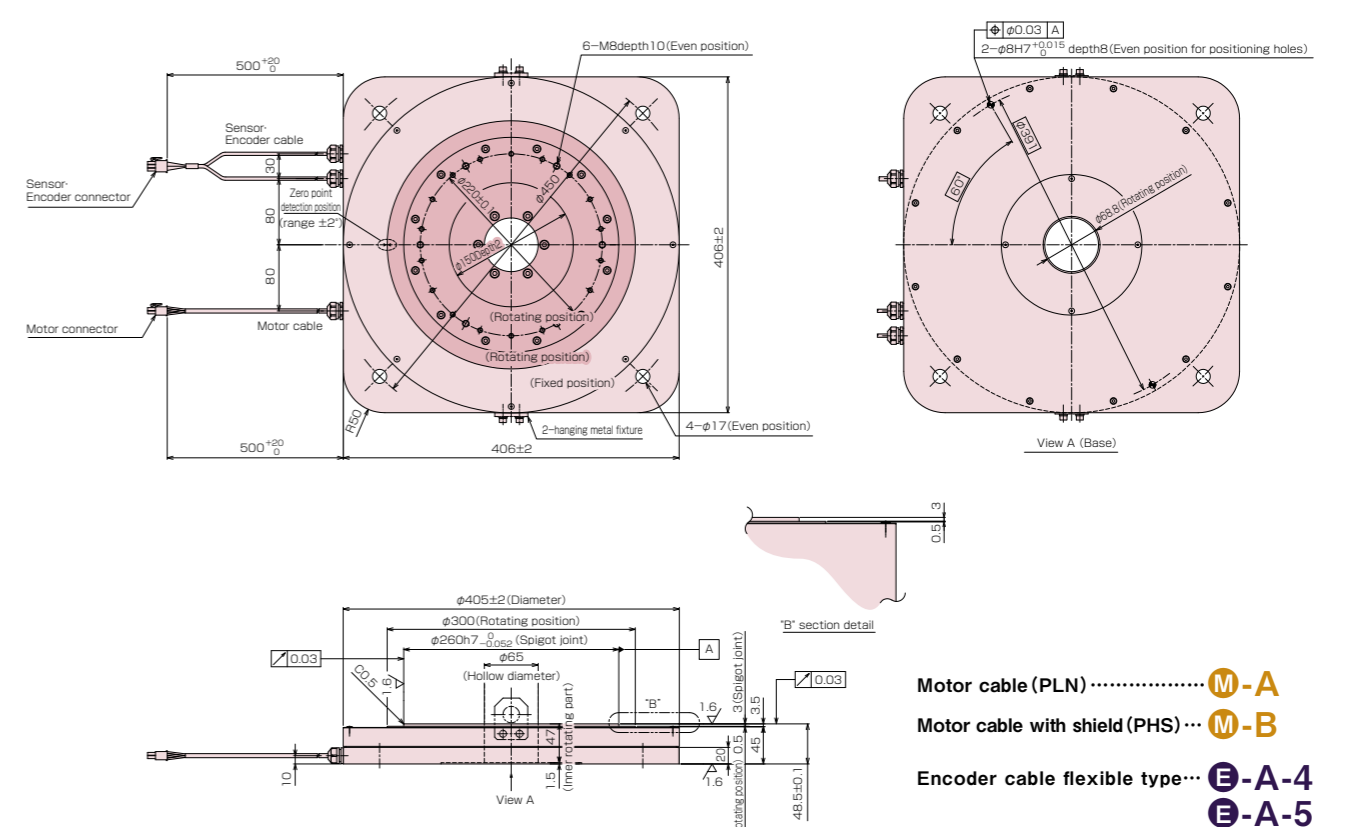

○ D400-40-L
NMR-FUDBA2C-801A

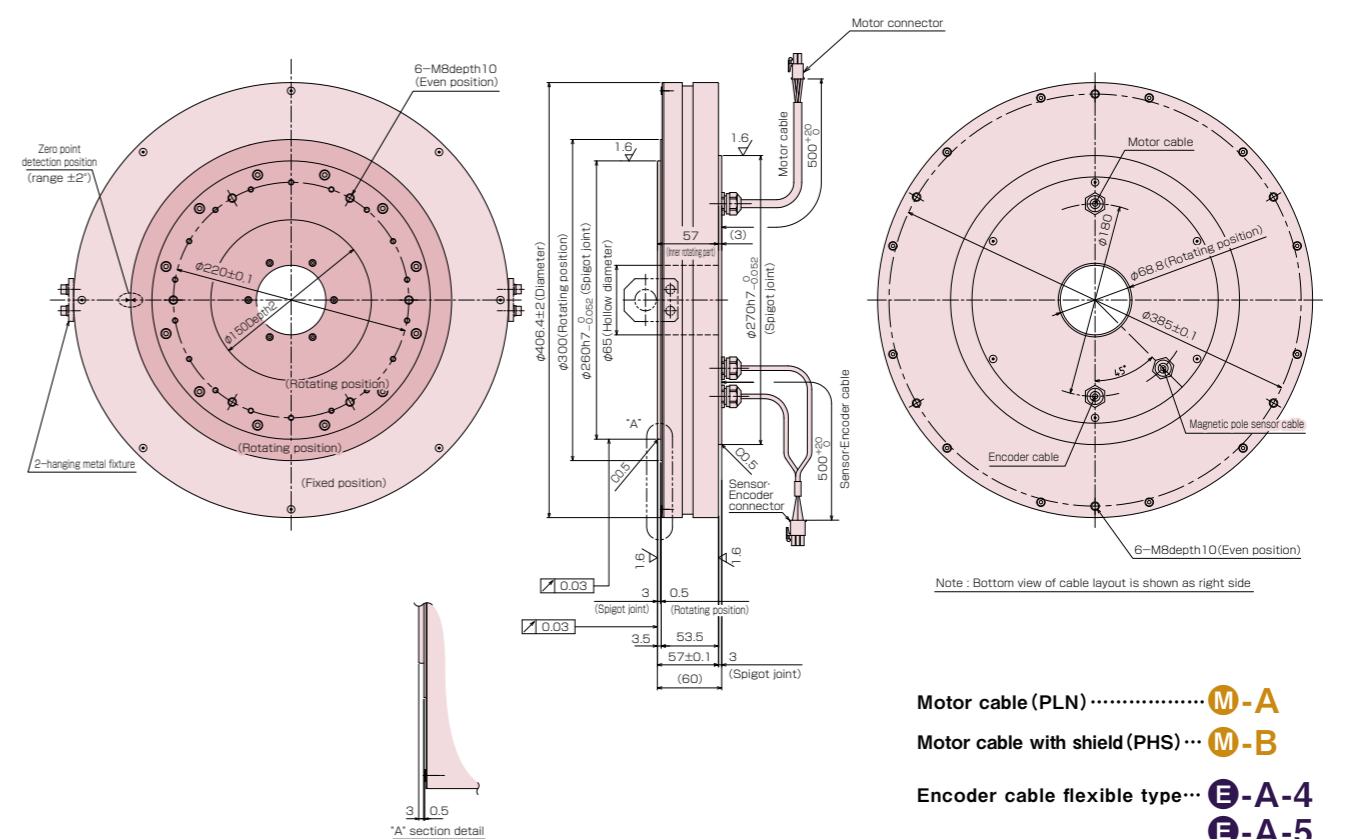

TDISC D series dimensions

D400-100-F
NMR-FFFBA2C-252A

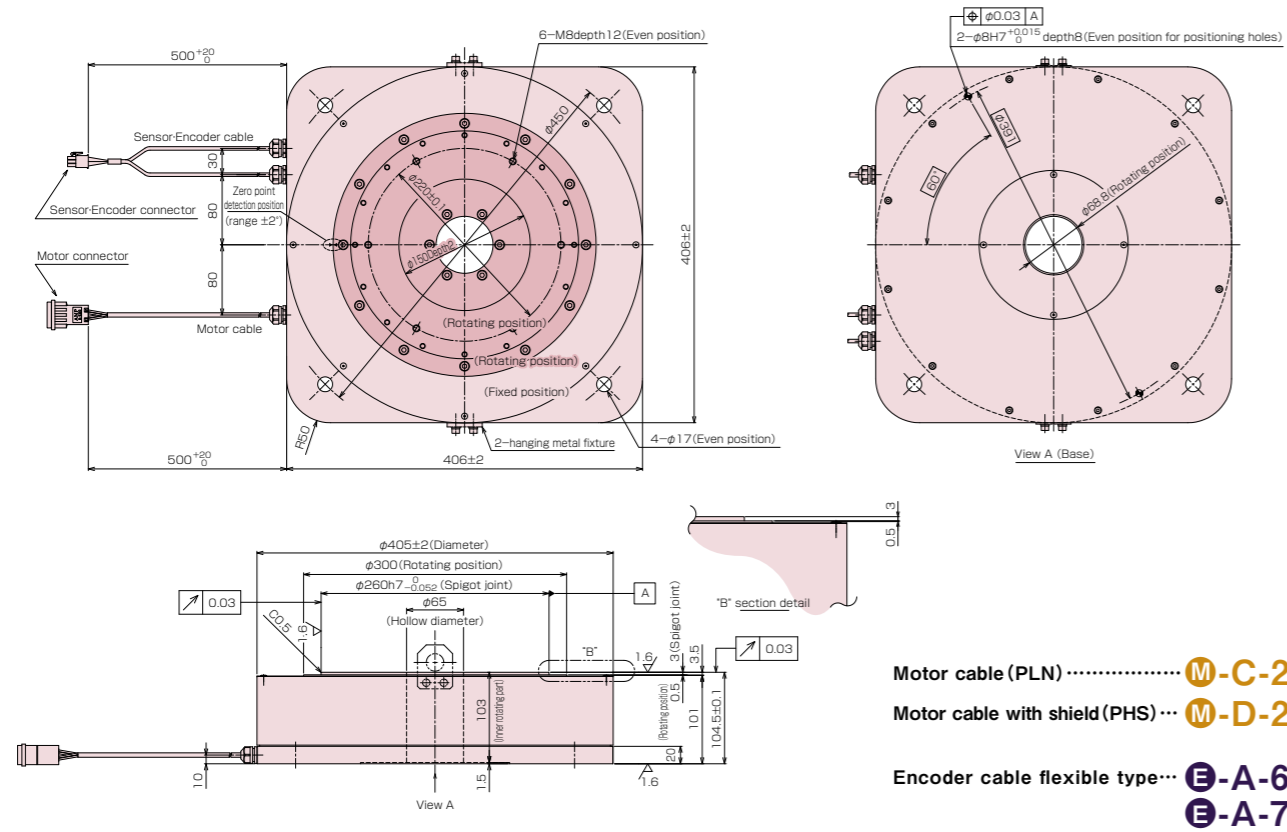

D400-100-L
NMR-FUFBA2C-252A

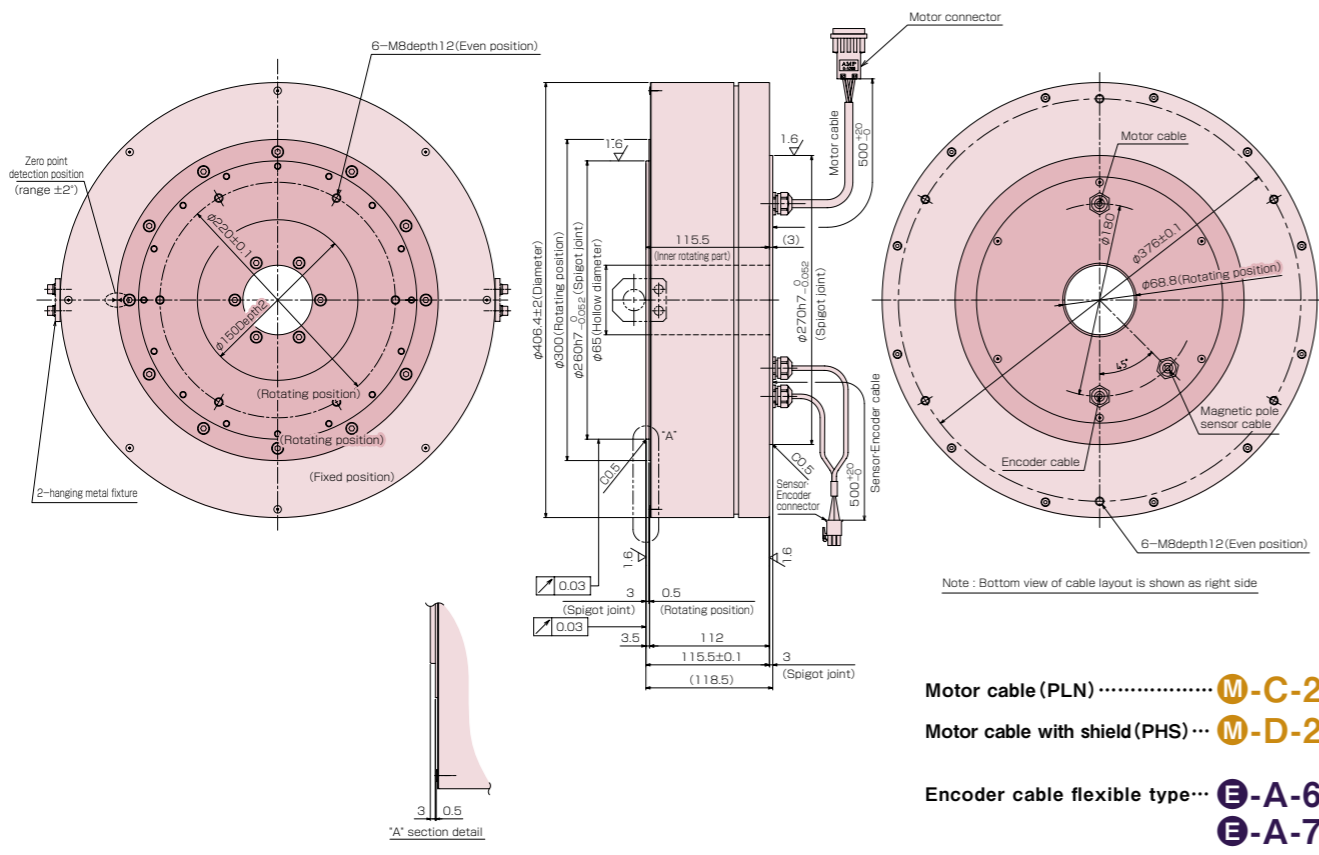

TDISC D series dimensions

D400-175-L
NMR-FUIBA2D-212AZ (0.66rps specification)
NMR-FUIBA2D-472AZ (1.5rps specification)

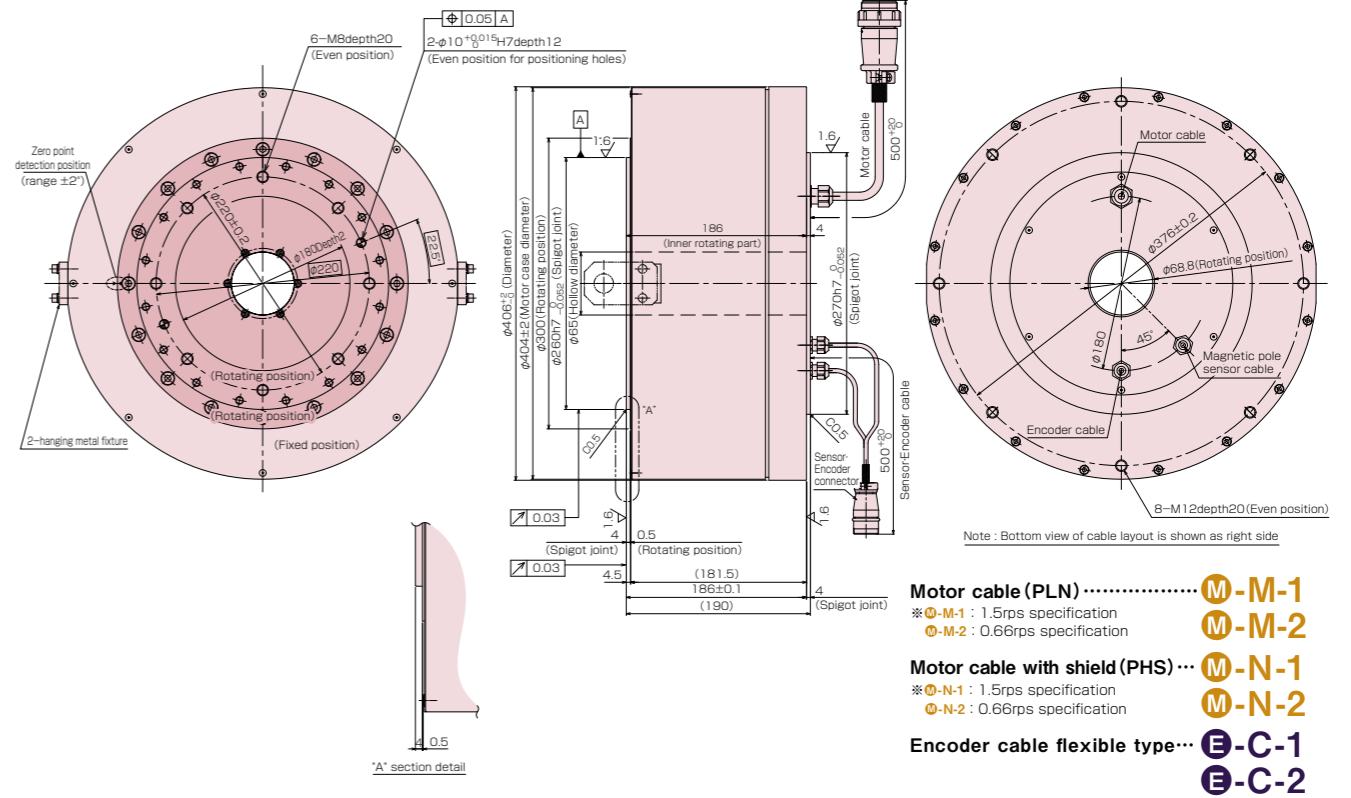

D400-275-L (High rigidity type)
NMR-FUVGA2A-662A (Incremental)
NMR-FUVHA2A-662A (Absolute)

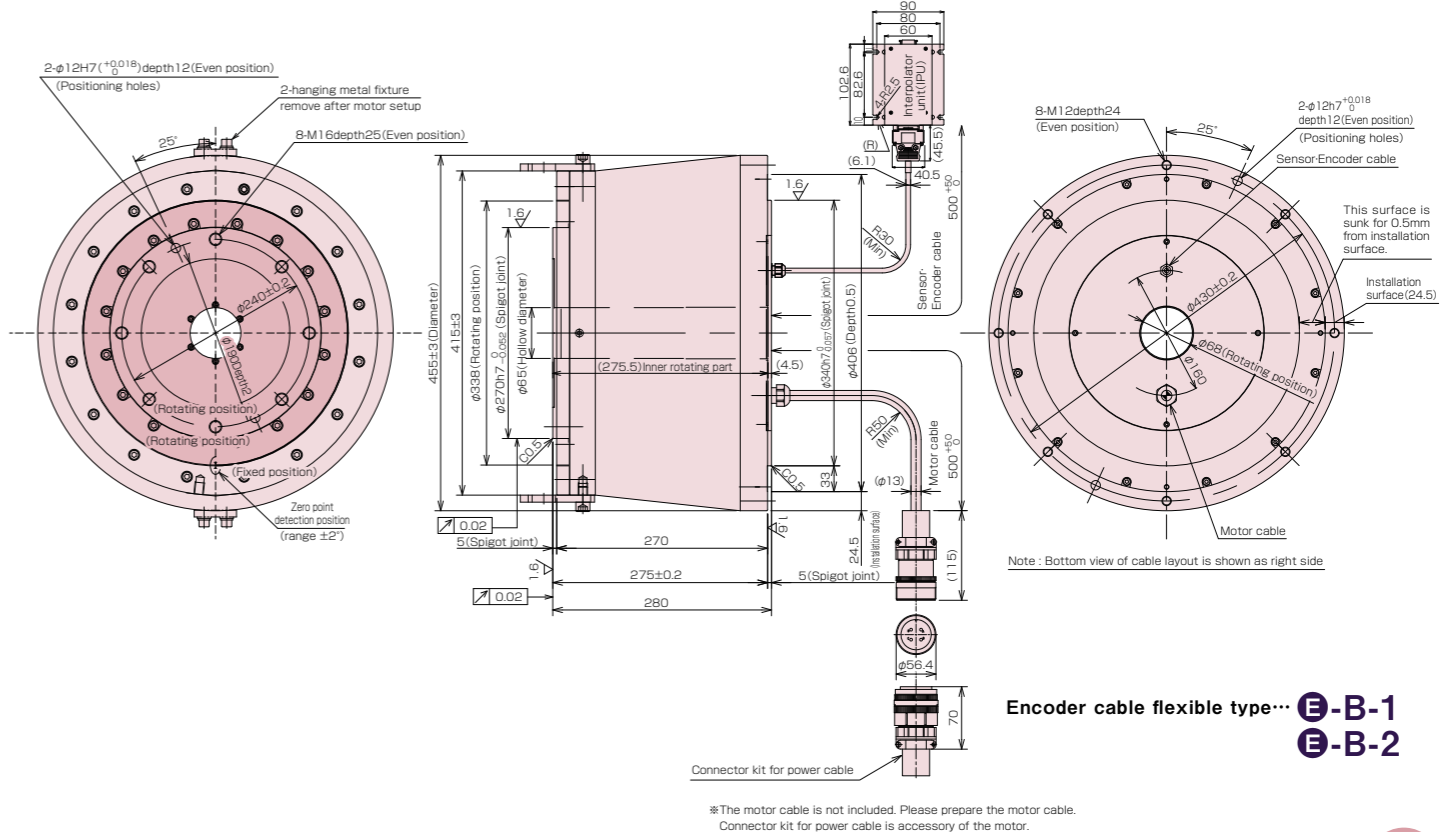

TDISC D series dimensions

D630-125-L
NMR-FVGBA2C-322A

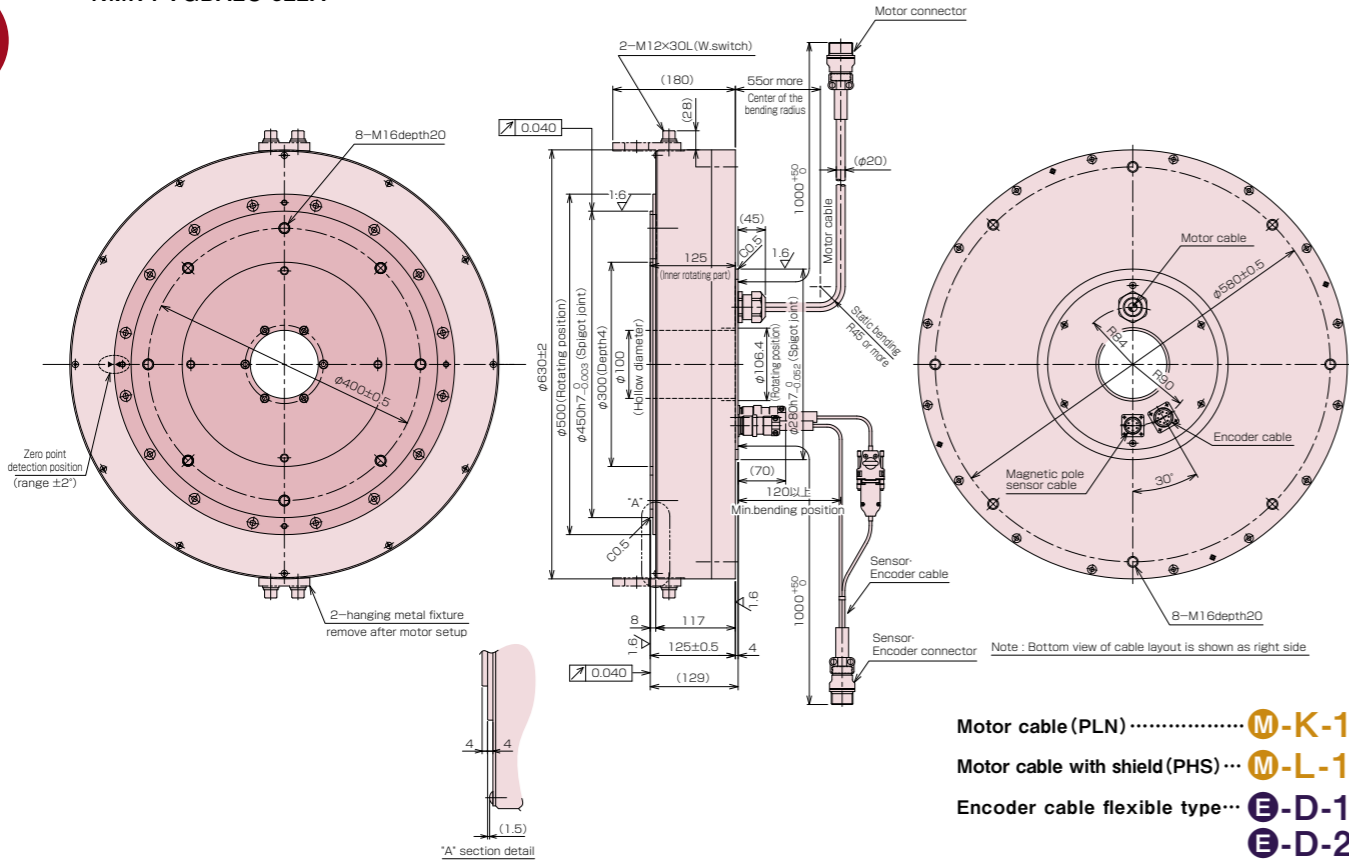

- Motor cable (PLN) **M-K-1**
- Motor cable with shield (PHS) ... **M-L-1**
- Encoder cable flexible type... **E-D-1**
E-D-2

TDISC D series dimensions

D630-225-L
NMR-FVKBA2B-872A

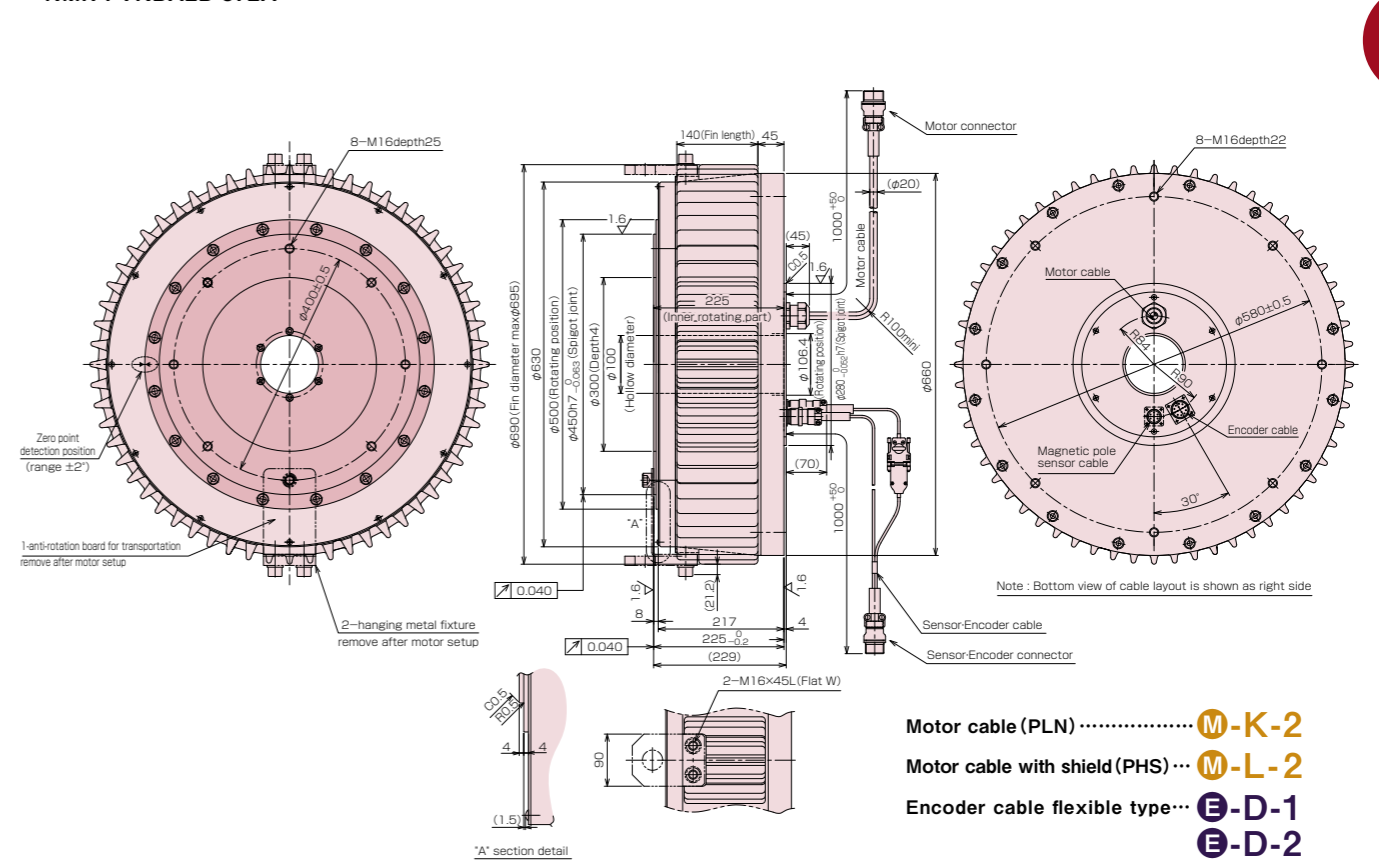

- Motor cable (PLN) **M-K-2**
- Motor cable with shield (PHS) ... **M-L-2**
- Encoder cable flexible type... **E-D-1**
E-D-2

D630-175-L
NMR-FVIBA2C-672A

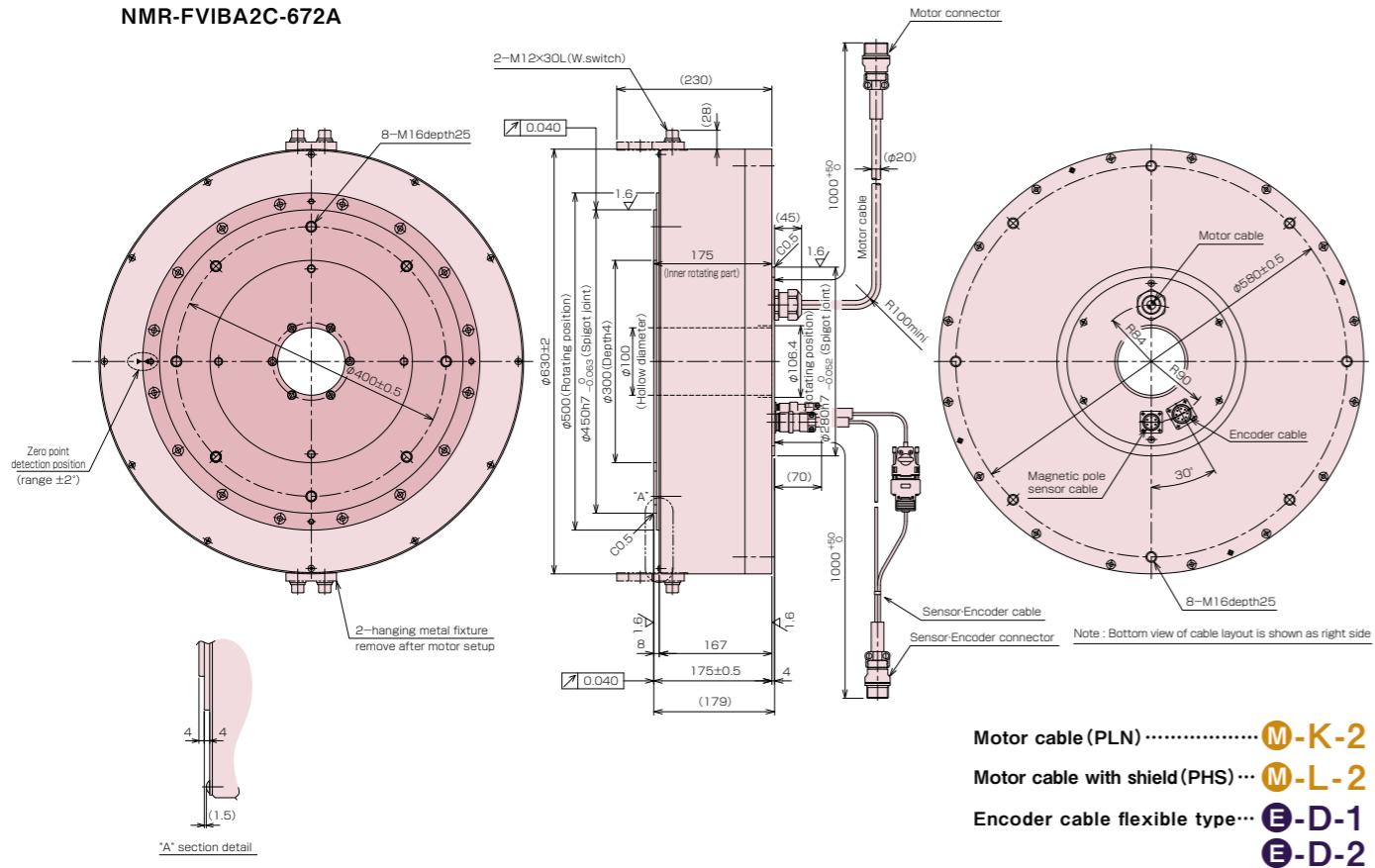

- Motor cable (PLN) **M-K-2**
- Motor cable with shield (PHS) ... **M-L-2**
- Encoder cable flexible type... **E-D-1**
E-D-2

D630-470-F
NMR-FGPHA2A-133AZG

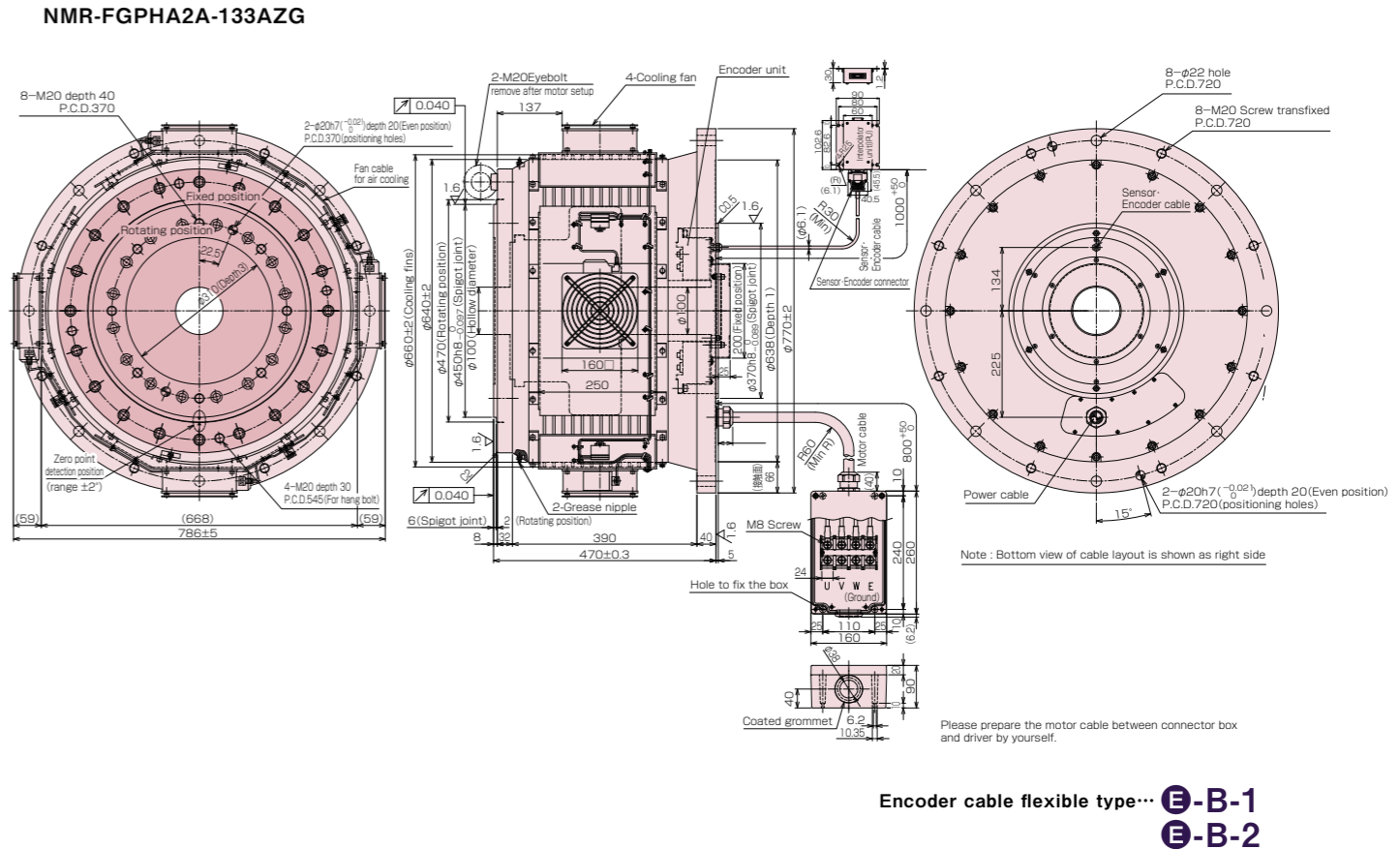

- Encoder cable flexible type... **E-B-1**
E-B-2

High response type



TDISC HD series Motor torque characters

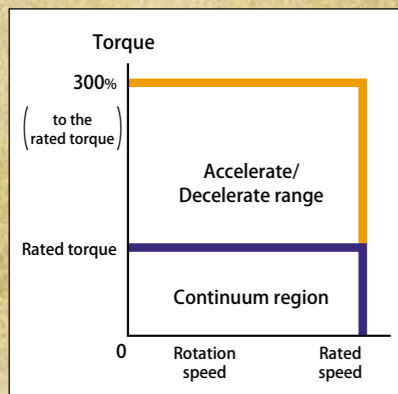

■ D250-200-L

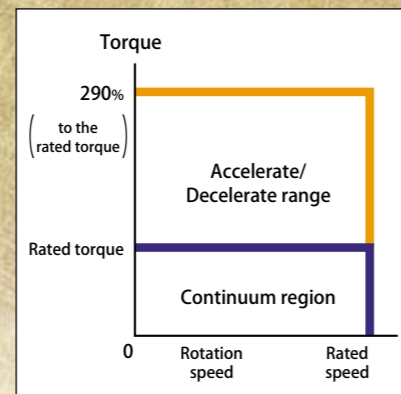

■ D170-225-L

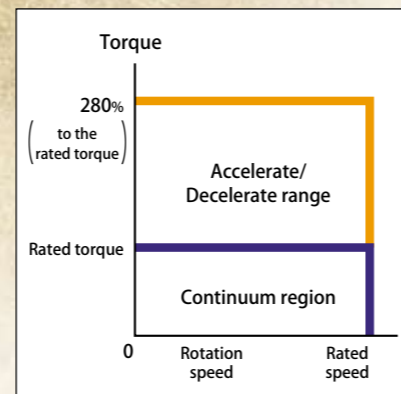

■ D140-160-F/L
D140-185-F/L

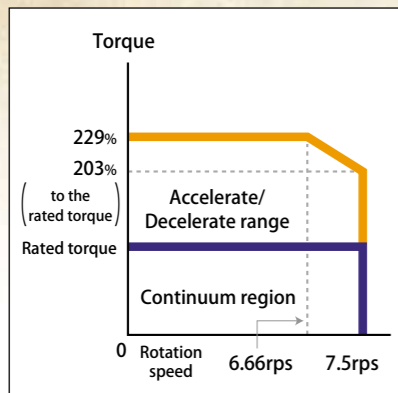

■ D140-160-LG
(Forced air cooling specification)
※The characteristic is when forced air cooling specification is used

TDISC HD series Specifications

Motor type	D140-160-F		D140-160-L		D140-185-F		D140-185-L	
	Model	NMR- mm(φ)	Frangé type FCHBA2D-661A	Frangé-less FRHBA2D-661A	Frangé type FCIBA2D-751A	Frangé-less FRIBA2D-751A	Frangé type FCIBA2D-751A	Frangé-less FRIBA2D-751A
External	mm(φ)	140	140	140	140	140	140	140
Height	mm	160	160	160	185	185	185	185
Rated torque	N·m	21	21	21	24	24	24	24
Max. torque	N·m	58.8	58.8	58.8	67.2	67.2	67.2	67.2
Rated output	W	660	660	660	753	753	753	753
Rated current	A	5.8	5.8	5.8	6.93	6.93	6.93	6.93
Absolute position accuracy ^{※1}	sec.	±15(Option)						
Allowable moment load ^{※2}	N·m	116.3	116.3	116.3	116.3	116.3	116.3	116.3
Allowable axial load ^{※2}	kN	7.9	7.9	7.9	7.9	7.9	7.9	7.9
Radial run out (No load)	μm	20(Standard)/10(Option)						
Axial run out (No load)	μm	20(Standard)/10(Option)						
Rotor inertia	kg·m ²	0.00302	0.00302	0.00302	0.00362	0.00362	0.00362	0.00362
Mass	kg	14.5	14.1	14.1	16.6	16.6	16.6	16.2
Magnetic pole detection method		Automatic						

Motor type	D170-225-L		D250-200-L	
	Model	NMR- mm(φ)	Frangé-less FSNBA2B-202AZ	Frangé-less FTJBA2F-302AZ
External	mm(φ)	180	180	265
Height	mm	225	210	210
Rated torque	N·m	53	115	115
Max. torque	N·m	154	345	345
Rated output	W	2000	3100	3100
Rated current	A	11.46	20.2	20.2
Absolute position accuracy ^{※1}	sec.	±15(Option)		
Allowable moment load ^{※2}	N·m	80	500	500
Allowable axial load ^{※2}	kN	6	15	15
Radial run out (No load)	μm	20(Standard)/10(Option)	25(Standard)/10(Option)	25(Standard)/10(Option)
Axial run out (No load)	μm	20(Standard)/10(Option)	25(Standard)/10(Option)	25(Standard)/10(Option)
Rotor inertia	kg·m ²	0.020	0.10	0.10
Mass	kg	30.3	52.5	52.5
Magnetic pole detection method		Hall sensor		

Motor type	D140-160-LG(Forced air cooling specification)	
	Model	NMR- mm(φ)
External	mm(φ)	158.6
Height	mm	160
Rated torque	N·m	27.5 ^{※3}
Max. torque	N·m	63
Rated output	W	1310 ^{※3}
Rated current	A	10 ^{※3}
Absolute position accuracy ^{※1}	sec.	±15(Option)
Allowable moment load ^{※2}	N·m	50
Allowable axial load ^{※2}	kN	3
Radial run out (No load)	μm	20(Standard)/10(Option)
Axial run out (No load)	μm	20(Standard)/10(Option)
Rotor inertia	kg·m ²	0.00266
Mass	kg	11.6
Magnetic pole detection method		Automatic

※In order to maintain accuracy and prevent uneven wear by lack of bearing grease, please rotate the output axis for 90 deg or more in certain period.
 ※1 The value is only when the absolute position compensation option is used. Refer to P43 [Absolute position compensation] for details.
 ※2 Life of bearing and run out depend on a load.
 ※3 The value is when forced air-cooling is used.

Assembling encoder specifications

Motor type	Detecting pulse (ppr)	Electrical resolution (sec)	Rated speed (rps)	Encoder type	Interpolator ^{※1}	Model ^{※2}	External connector diagram No.	
							VCII series	VPS series
D140	1,000,000	1.296	5.0	Incremental	Built-in	NSR-RJLH1*~15	①-1→P53 references	②-1→P61 references
	2,000,000	0.648	5.0			NSR-RJMH1*~15		
	10,240,000	0.127	5.0			NSR-RRSH2*~10		
D140-160G (Forced air cooling)	1,000,000	1.296	7.5	Incremental	Built-in	NSR-RJLH1*~15	①-1→P53 references	-
	1,800,000 ^{※3}	0.720	7.5			NSR-RJMM1*~15		
	2,000,000	0.648	6.7 ^{※4}			NSR-RJMH1*~15		
D170	1,000,000	1.296	6.0	Incremental	Built-in	NSR-RELH1*~10	①-1→P53 references	-
	2,000,000	0.648	5.0			NCR-REMH1*~10		
D250	900,000	1.440	4.16	Incremental	Built-in	NSR-RELK1*~10	-	-
	1,800,000	0.720	4.16			NSR-REMK1*~10		

※1 If the external type interpolator is selected, P39 interpolator unit (IPU) is installed separately. In such case, the combination of encoder cable is P40 ②-B-1 ②-B-2.
 ※2 * mark refers to the design order (Non-marking or start from A~).
 ※3 When the encoder is selected, Servo driver VPS series is not selected.
 ※4 When Servo driver VPS series is selected, the rps is 5rps.

● **TDISC HD series dimensions**

○ **D140-160-F**
NMR-FCHBA2D-661A

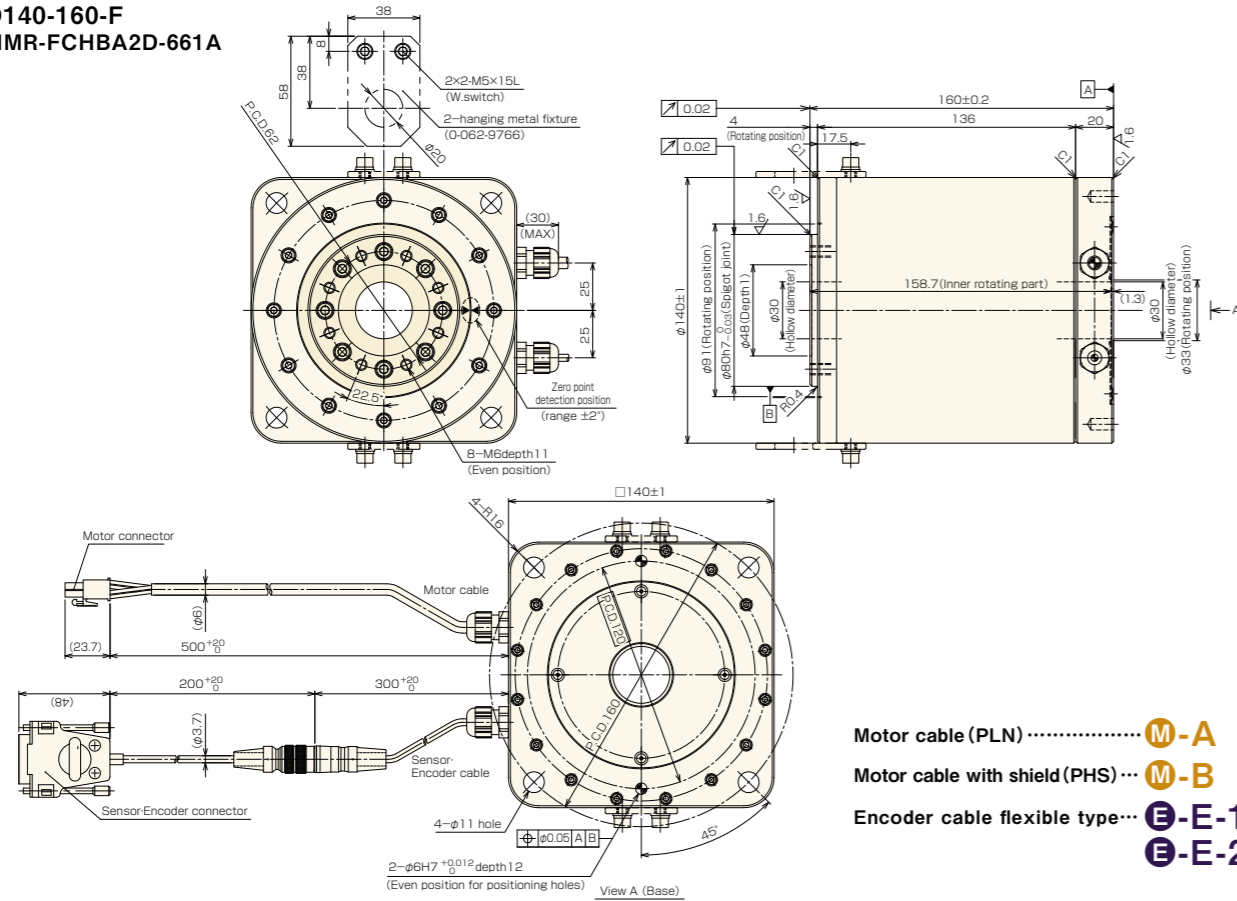

● **T DISC HD series dimensions**

○ **D140-185-F**
NMR-FCIBA2D-751A

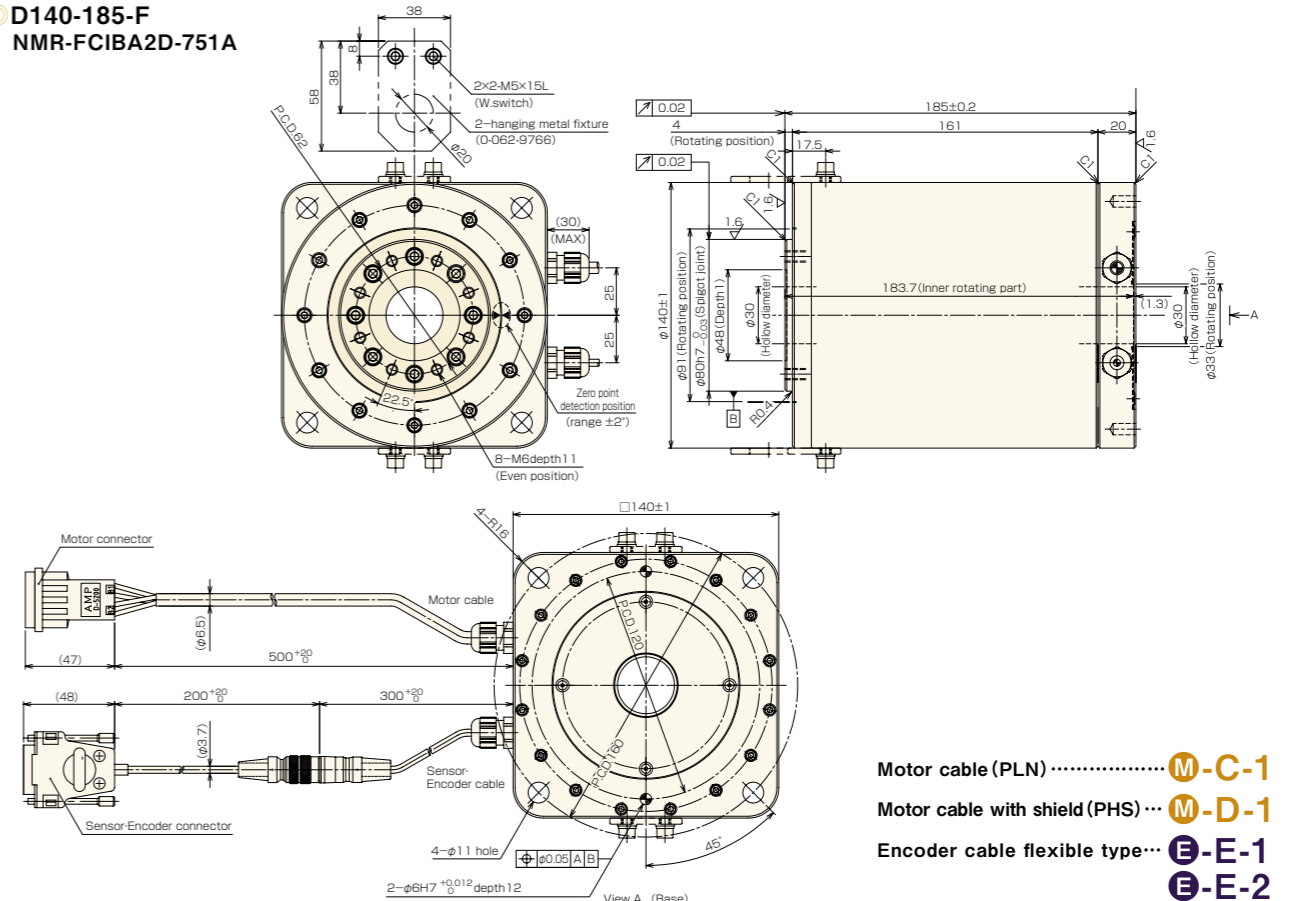

○ **D140-160-L**
NMR-FRHBA2D-661A

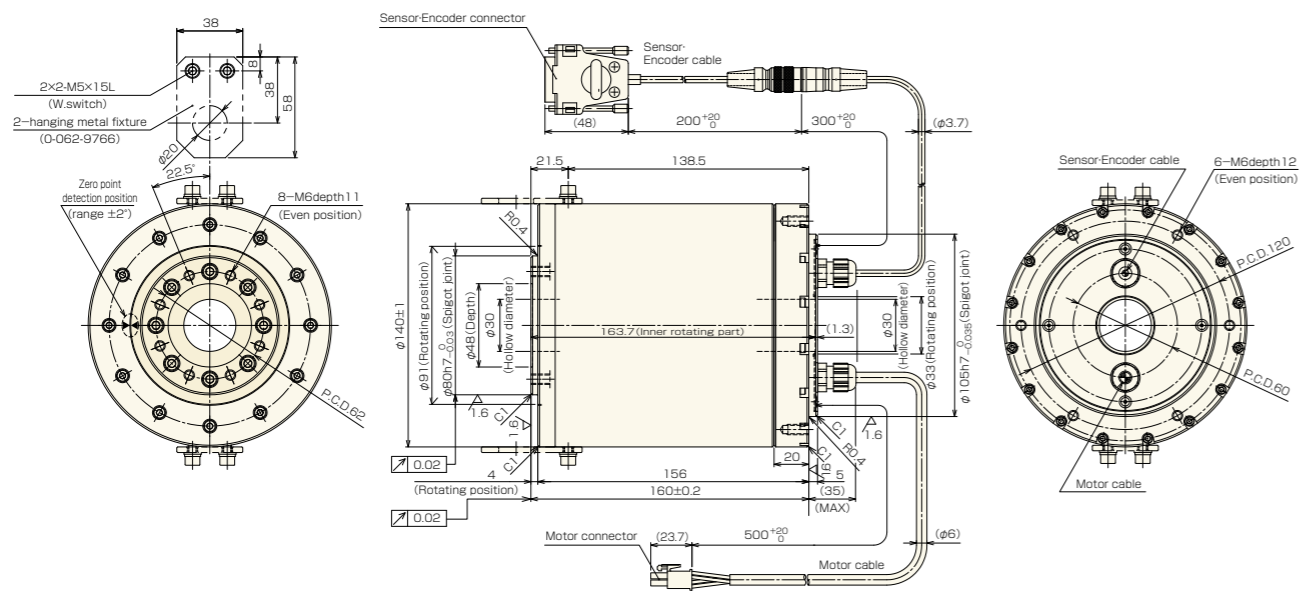

○ **D140-185-L**
NMR-FRIBA2D-751A

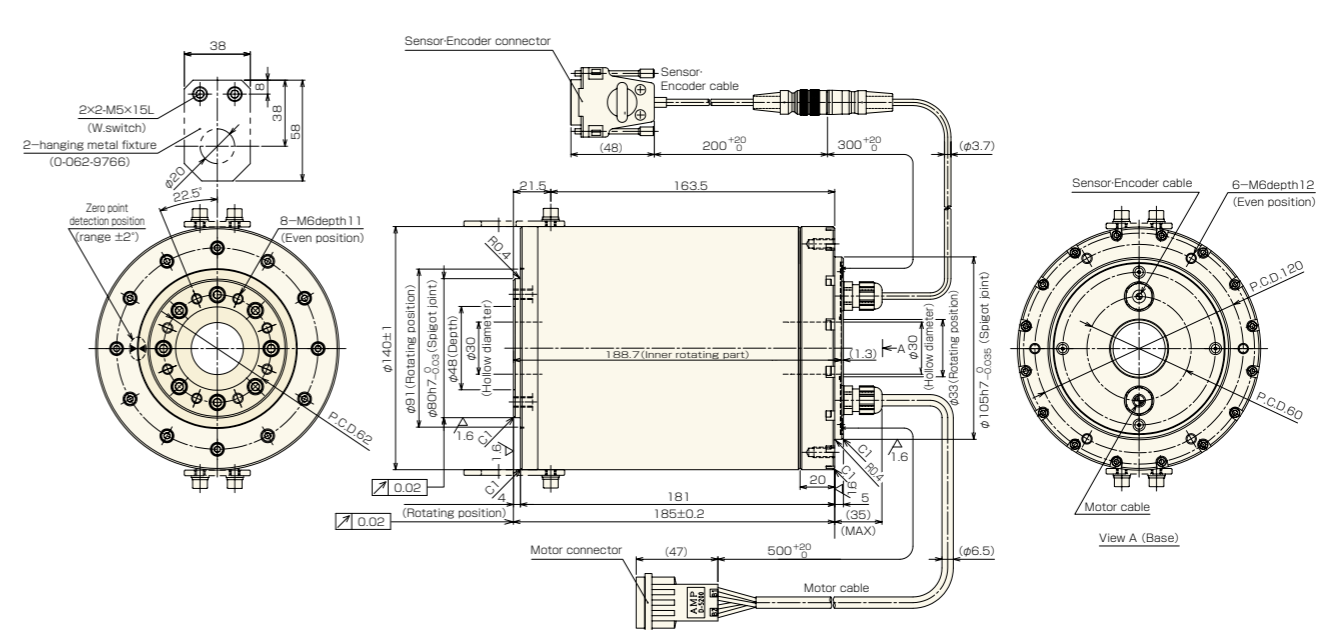

TDISC HD series dimensions

D170-225-L
NMR-FSNBA2B-202AZ

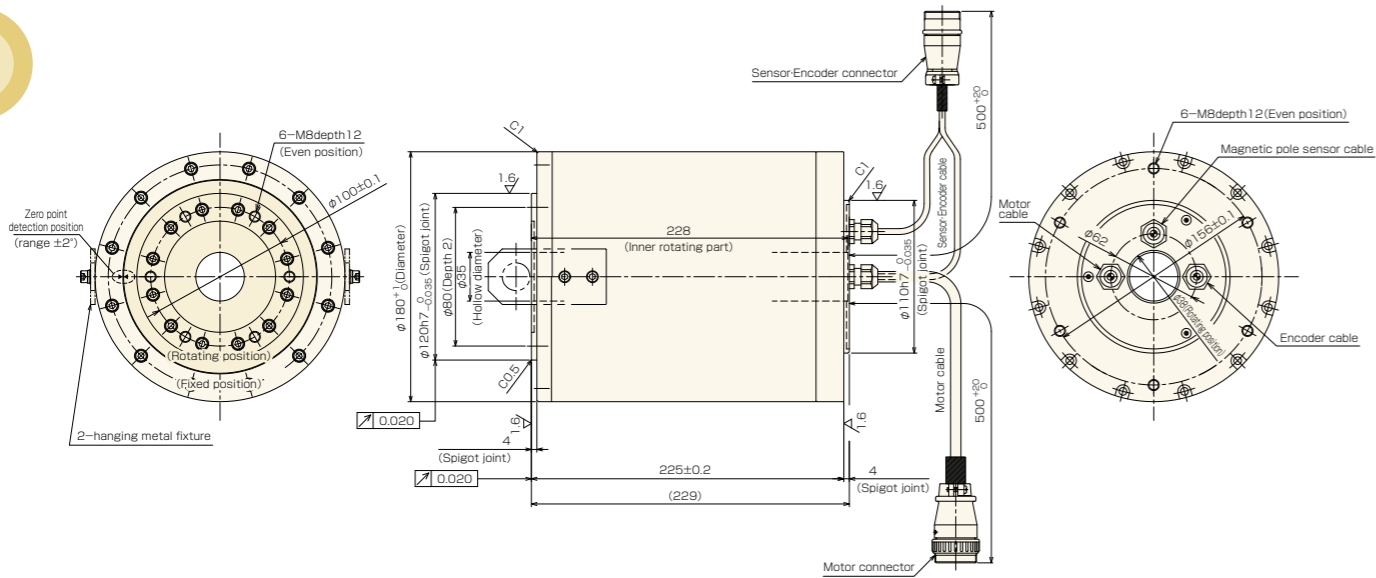

- Motor cable (PLN) **M-I**
- Motor cable with shield (PHS) ... **M-J**
- Encoder cable flexible type ... **E-C-1**
E-C-2

D250-200-L
NMR-FTJBA2F-302AZ

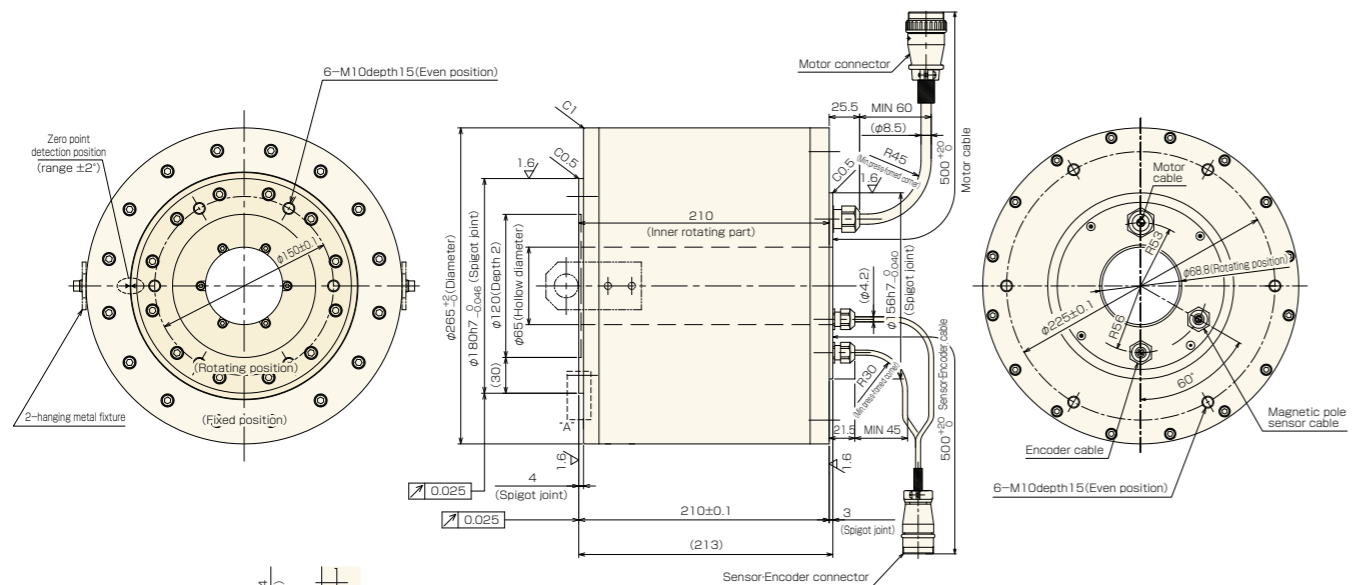

- Motor cable (PLN) **M-I**
- Motor cable with shield (PHS) ... **M-J**
- Encoder cable flexible type ... **E-C-1**
E-C-2

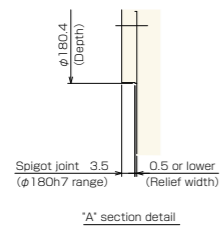

TDISC HD series dimensions

D140-160-LG (Forced air cooling specification)
NMR-FRHBA2A-112AG

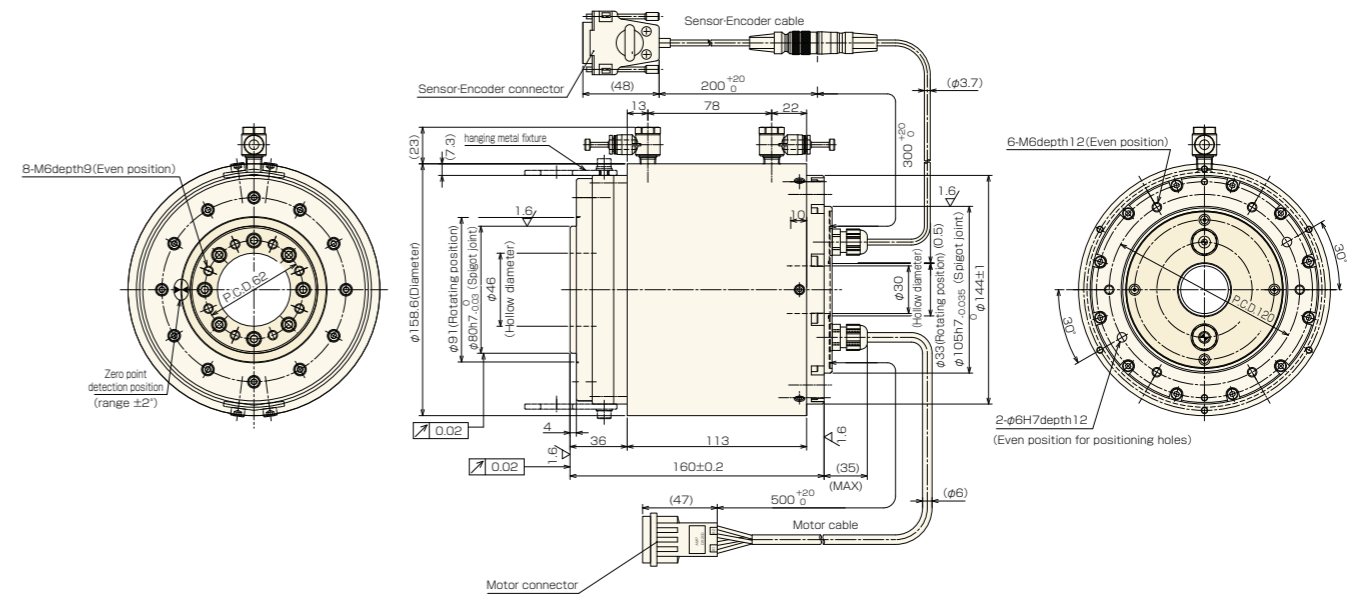

- Motor cable (PLN) **M-C-1**
- Motor cable with shield (PHS) ... **M-D-1**
- Encoder cable flexible type ... **E-E-1**
E-E-2



Standard type

TDISC ND-c•ND series Motor torque characters

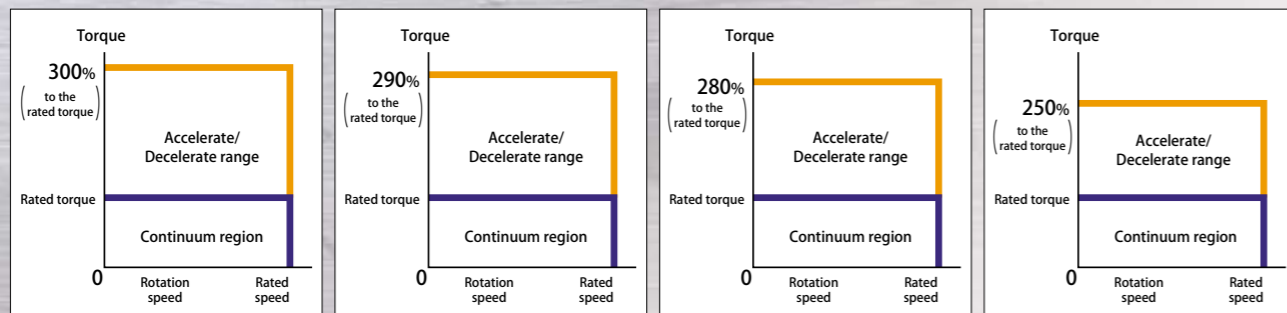

【ND-c】ND110-65-FC/ND110-85-FC
ND140-70-LC/ND140-95-LC
ND180-70-LC/ND180-95-LC
ND250-70-LC

【ND】ND110-100-L

【ND】ND400-110-L

【ND-c】ND250-95-LC
ND400-70-LC/ND400-95-LC

【ND】ND400-55-F

【ND】ND110-50-F
ND180-55-F/ND180-110-L
ND250-55-F/ND250-110-L

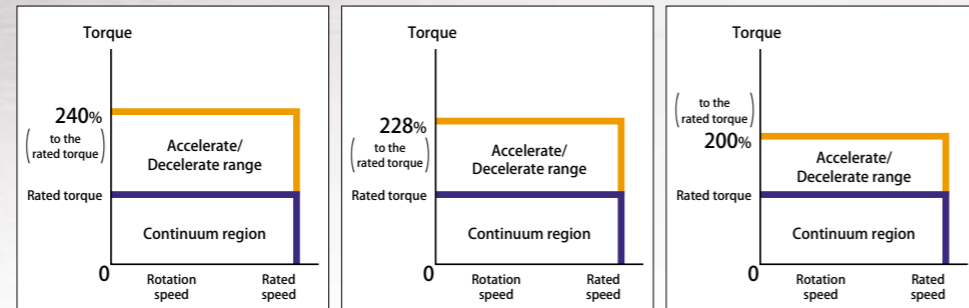

【ND-c】ND400-120-LC (1rps specification)

【ND-c】ND400-120-LC (4.16rps specification)

【ND-c】ND400-175-L

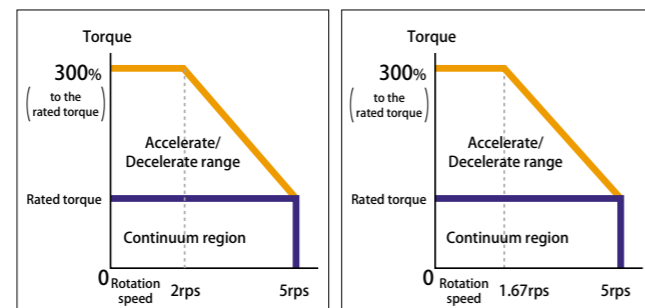

【ND】
When operating ND110-50-F/ND180-55-F at AC100V

【ND-c】
When operation ND100-85-FC/ND140-70-LC at AC100V

TDISC ND-c series Specifications

Motor type	ND110-65-FC		ND110-85-FC		ND140-70-LC		ND140-95-LC		
	Model #1	NMR-Frange type	Model #1	NMR-Frange type	Model #1	NMR-Frange type	Model #1	NMR-Frange type	
External	mm(φ)	112	112	145	145	145	145	145	
Height	mm	66	86	73	73	98	98	98	
Rated torque	Nm	2.4	4.8	4.8	4.8	9.6	9.6	9.6	
Max. torque	Nm	7.2	14.4(12) #2	14.4	14.4	28.8	28.8	28.8	
Rated output	W	75	150	150	150	300	300	300	
Rated current	A	2	3.4	3.4	2.7	5.4	5.4	5.4	
Absolute position accuracy #4	sec.	±15(20) #3 (Option)		±15(Option)		±15(Option)		±15(Option)	
Allowable moment load #5	Nm	4.6	4.8	8.4	8.4	8.4	8.4	8.4	
Allowable axial load #5	kN	0.15	0.15	0.2	0.2	0.2	0.2	0.2	
Radial run out (No load)	μm	20(Standard) / 10(Option)	50(Standard) / 10(Option)	30(Standard) / 10(Option)	30(Standard) / 10(Option)	50(Standard) / 10(Option)	50(Standard) / 10(Option)	50(Standard) / 10(Option)	
Axial run out (No load)	μm	20(Standard) / 10(Option)	50(Standard) / 10(Option)	30(Standard) / 10(Option)	30(Standard) / 10(Option)	50(Standard) / 10(Option)	50(Standard) / 10(Option)	50(Standard) / 10(Option)	
Rotor inertia #6	kg·m ²	0.00041(0.00045)	0.00063(0.00067)	0.00088(0.00093)	0.00088(0.00093)	0.00147(0.00151)	0.00147(0.00151)	0.00147(0.00151)	
Mass	kg	2.2	3.4	4.4	4.4	5.9	5.9	5.9	
Magnetic pole detection method	kg	Incremental→Hall sensor / Absolute→Absolute position detection							

Motor type	ND180-70-LC		ND180-95-LC		ND250-70-LC		ND250-95-LC	
	Model #1	NMR-Frange type	Model #1	NMR-Frange type	Model #1	NMR-Frange type	Model #1	NMR-Frange type
External	mm(φ)	180	180	260	260	260	260	260
Height	mm	67	94	73	73	98	98	98
Rated torque	Nm	9	18	27	27	45	45	45
Max. torque	Nm	27	54	81	81	112.5	112.5	112.5
Rated output	W	282	564	508	508	848	848	848
Rated current	A	2.6	4.3	4.5	4.5	6.8	6.8	6.8
Absolute position accuracy #4	sec.	±15(Option)						
Allowable moment load #5	Nm	15	15	140	140	140	140	140
Allowable axial load #5	kN	0.6	0.6	2.5	2.5	2.5	2.5	2.5
Radial run out (No load)	μm	50(Standard) / 10(Option)						
Axial run out (No load)	μm	50(Standard) / 10(Option)						
Rotor inertia #6	kg·m ²	0.0034(0.0034)	0.0048(0.0048)	0.022(0.022)	0.022(0.022)	0.034(0.034)	0.034(0.034)	0.034(0.034)
Mass	kg	6.0	9.3	12.8	12.8	19	19	19
Magnetic pole detection method	kg	Incremental→Hall sensor / Absolute→Absolute position detection						

Motor type	ND400-70-LC		ND400-95-LC		ND400-120-LC (1rps specification)		ND400-120-LC (4.16rps specification)		
	Model #1	NMR-Frange type	Model #1	NMR-Frange type	Model #1	NMR-Frange type	Model #1	NMR-Frange type	
External	mm(φ)	408	408	408	408	408	408	408	
Height	mm	73	98	126	126	126	126	126	
Rated torque	Nm	76	152	250	250	250	250	250	
Max. torque	Nm	190	380	600	600	570	570	570	
Rated output	W	955	1910	1570	1570	6540	6540	6540	
Rated current	A	6.8	13.4	14.4	14.4	40.8	40.8	40.8	
Absolute position accuracy #4	sec.	±15(Option)							
Allowable moment load #5	Nm	170	170	1280	1280	1280	1280	1280	
Allowable axial load #5	kN	3	3	16	16	16	16	16	
Radial run out (No load)	μm	50(Standard) / 10(Option)							
Axial run out (No load)	μm	50(Standard) / 10(Option)							
Rotor inertia #6	kg·m ²	0.153(0.153)	0.223(0.223)	(0.350)	(0.350)	(0.350)	(0.350)	(0.350)	
Mass	kg	30.5	44.5	63.6	63.6	63.6	63.6	63.6	
Magnetic pole detection method	kg	Incremental→Hall sensor / Absolute→Absolute position detection					Absolute position detection		

*In order to maintain accuracy and prevent uneven wear by lack of bearing grease, please rotate the output axis for 90 deg or more in certain period.

*1 Type in () depends on encoder type.

I: Encoder type Incremental (Built-in interpolator unit type)

G: Encoder type Incremental (Separated interpolator unit type)

H: Encoder type Absolute (Separated interpolator unit type)

*2 The value of () is when VPS series is used.

*3 The value of () is when incremental (built-in interpolator unit) type is used.

*4 The value is only when the absolute position compensation option is used. Refer to P43 [Absolute position compensation] for details.

*5 Life of bearing and run out depend on a load.

*6 The value of () is when absolute encoder type is used.

Assembling encoder specifications

Motor type	Detecting pulse (ppr)	Electrical resolution (sec)	Rated speed (rps)	Encoder type #1	Interpolator #2	Model #3	External connector diagram No.	
							VCII series	VPS series
ND110-C/140-C	640,000	2.030	5.0	Incremental	Built-in	NSR-RSMU1*-05	①-1→P53 references	②-1→P61 references
	1,280,000	1.010	3.0	Incremental	Built-in	NSR-RSNU1*-05	①-1→P53 references	②-1→P61 references
	3,276,800	0.396	5.0	Incremental	Separated	NSR-RGSU2*-05	①-2→P54 references	②-2→P62 references
	2,097,152	0.620	5.0	Absolute	Separated	NSR-RPSW2*-05	①-2→P54 references	②-2→P62 references
ND180-C	840,000	1.540	5.0	Incremental	Built-in	NSR-RSMV1*-05	①-1→P53 references	②-1→P61 references
	4,300,800	0.300	5.0	Incremental	Separated	NSR-RGSV2*-05	①-2→P54 references	②-2→P62 references
	2,097,152	0.620	5.0	Absolute	Separated	NSR-RPSW2*-05	①-2→P54 references	②-2→P62 references
	1,344,000	0.960	3.0	Incremental	Built-in	NSR-RSU1*-05	①-1→P53 references	②-1→P61 references
ND250-C	7,168,000	0.180	3.0	Incremental	Separated	NSR-RGSY2*-05	①-2→P54 references	②-2→P62 references
	6,815,744	0.190	3.0	Absolute	Separated	NSR-RPST2*-05	①-2→P54 references	②-2→P62 references
	1,344,000	0.960	2.0	Incremental	Built-in	NSR-RSU2*-05	①-1→P53 references	②-1→P61 references
	7,168,000	0.180	2.0	Incremental	Separated	NSR-RGSZ2*-05	①-2→P54 references	②-2→P62 references
ND400-70-C/95-C	6,815,744	0.190	2.0	Absolute	Separated	NSR-RPST2*-05	①-2→P54 references	②-2→P62 references
	1,048,576	1.240	1/4.16	Absolute	Separated	NSR-RPSS2*	①-2→P54 references	—

*1 Absolute encoder is one resolution absolute value.

*2 If the external type interpolator is selected, P39 interpolator unit (IPU) is installed separately.

In such case, the combination of encoder cable is P40 ①-B-1 ②-B-2.

*3 * mark refers to the design order (Non-marking or start from A~).

TDISC ND series Specifications

Motor type		ND110-50-F	ND110-100-L	ND180-55-F	ND180-110-L
Model		NMR- NAMBA2A-071A	Frangé-less NPEBA2A-201A	Frangé type NDMGA2A-201A	Frangé-less NSFGA2B-701A
External	mm(φ)	112	112	180	180
Height	mm	50	95	58	117
Rated torque#2	Nm	2.4	7	9	27
Max. torque#2	Nm	7.2	20.3	27	81
Rated output	W	75	220	282	848
Rated current	A	2	3.4	2.6	7.2
Absolute position accuracy#3	sec.			±15(Option)	
Allowable moment load#4	Nm	4.6	4.6	32.4	89.9
Allowable axial load#4	kN	0.8	0.8	2.3	6.9
Radial run out (No load)#5	μm		20		
Axial run out (No load)#5	μm		20		
Rotor inertia	kg·m ²	0.00034	0.0011	0.0028	0.007
Mass	kg	1.9	4.7	5.5	11.5
Magnetic pole detection method		Automatic		Hall sensor	

Motor type		ND250-55-F	ND250-110-L	ND400-55-F	ND400-110-L
Model#1		NMR- NEM*A2B-401A	Frangé-less NTF*A2B-122A	Frangé type NFM*A2B-801A	Frangé-less NUF*A2B-252A
External	mm(φ)	250	260	408	408
Height	mm	58	117	58	117
Rated torque#2	Nm	27	82	76	215
Max. torque#2	Nm	81	246	190	603
Rated output	W	508	1545	955	2701
Rated current	A	4.5	12.8	6.8	16
Absolute position accuracy#3	sec.			±15(Option)	
Allowable moment load#4	Nm	109.9	337.4	520	1805.5
Allowable axial load#4	kN	4.1	13.3	13.7	44.6
Radial run out (No load)#5	μm		25		30
Axial run out (No load)#5	μm		25		30
Rotor inertia	kg·m ²	0.0208	0.0515	0.144	0.306
Mass	kg	10.2	22.8	28	61
Magnetic pole detection method		Incremental→Hall sensor / Absolute→Absolute position detection			

Motor type		ND400-175-L (1.5rps specification)	ND400-175-L (3rps specification)
Model#1		NMR- NUI*A2A-472AZ	Frangé-less NUI*A2A-862AZ
External	mm(φ)	404	404
Height	mm	186	186
Rated torque#2	Nm	500	450
Max. torque#2	Nm	1000	900
Rated output	W	4700	8600
Rated current	A	29.7	43
Absolute position accuracy#3	sec.		±15(Option)
Allowable moment load#4	Nm		1805.5
Allowable axial load#4	kN		44.6
Radial run out (No load)#5	μm		30
Axial run out (No load)#5	μm		30
Rotor inertia	kg·m ²		0.61
Mass	kg		117
Magnetic pole detection method		Incremental→Hall sensor / Absolute→Absolute position detection	

※ In order to maintain accuracy and prevent uneven wear by lack of bearing grease, please rotate the output axis for 90 deg or more in certain period.

※1 Type in () depends on encoder type.

G : Encoder type Incremental (Separated interpolator unit type)

H : Encoder type Absolute (Separated interpolator unit type)

※2 Please refer to P49-50 [VCII series], P59 [VPS series] for the details.

※3 The value is only when the absolute position compensation option is used. Refer to P43 [Absolute position compensation] for details.

※4 Life of bearing and run out depend on a load.

※5 Please consult with our sales dept. if you request high precision which is 10um or less of run-out accuracy.

Assembling encoder specifications

Motor type	Detecting pulse (ppr)	Electrical resolution (sec)	Rated speed (rps)	Encoder type #1	Interpolator	Model #2	External connection diagram No.
ND110	720,000	1.800	5.0	Incremental	Built-in	NSR-REMP1*-10-ND	①-1→P53 references ②-1→P61 references
ND180	4,300,800	0.302	5.0	Incremental	Separated	NSR-RQSV2*-05	
ND250	6,815,744	0.191	3.0	Absolute	Separated	NSR-RPST2*-05	
	7,168,000	0.181	3.0	Incremental	Separated	NSR-RQSY2*-05	
ND400-55/110	6,815,744	0.191	2.0	Absolute	Separated	NSR-RPST2*-05	①-2→P54 references ②-2→P62 references
	7,168,000	0.181	2.0	Incremental	Separated	NSR-RQS22*-05	
ND400-175	6,815,744	0.191	1.5 / 2 / 3	Absolute	Separated	NSR-RPST2*-05	
	7,168,000	0.181	1.5 / 2 / 3	Incremental	Separated	NSR-RQS22*-05	

※1 Absolute encoder is one resolution absolute value.

※2 * mark refers to the design order (Non-marking or start from A~).

TDISC ND-c series dimensions

ND110-65-FC NMR-CAEIA2A-071A (Incremental)
NMR-CAEGA2A-071A (Incremental:Separated interpolator unit (IPU) type)
NMR-CAEHA2A-071A (Absolute:Separated interpolator unit (IPU) type)

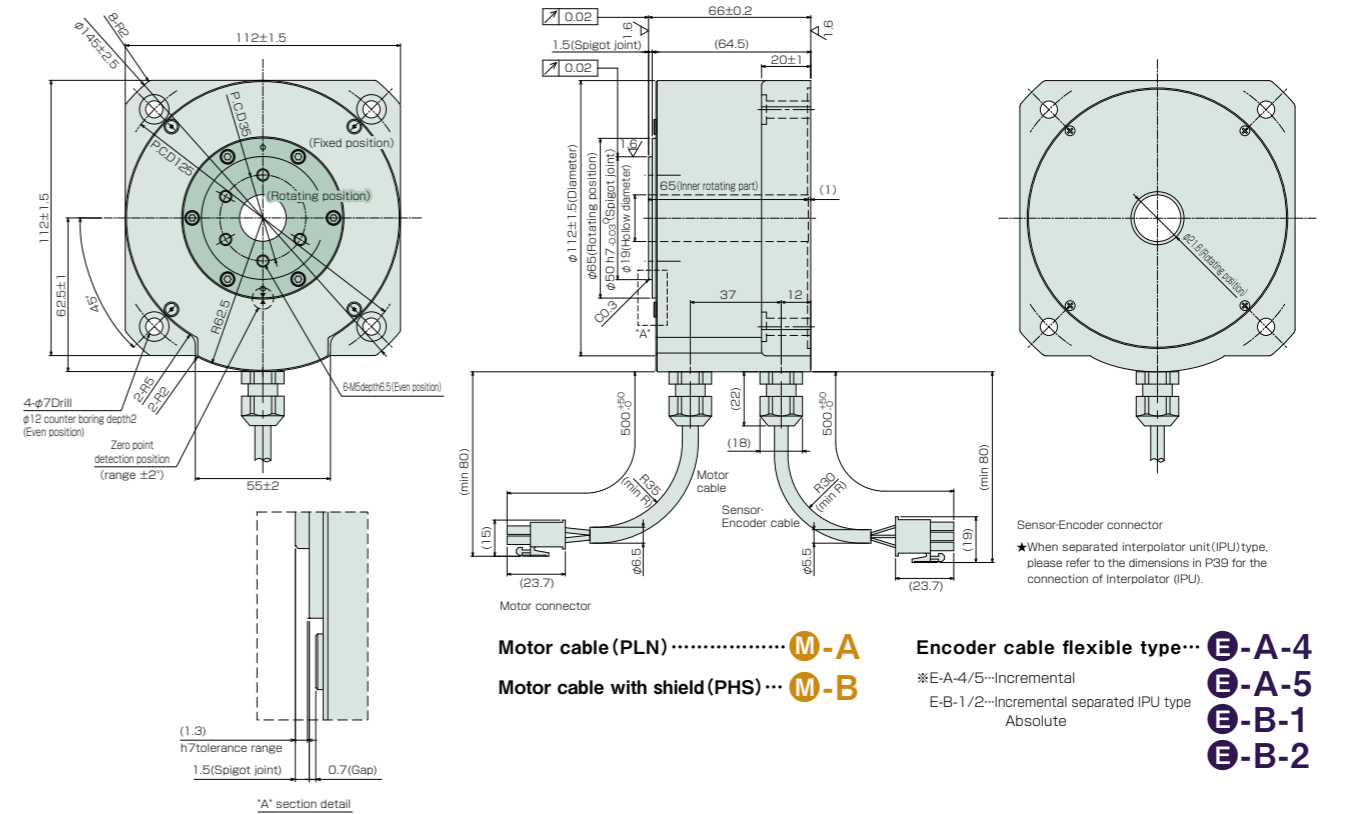

ND110-85-FC NMR-CAUIA2A-151A (Incremental)
NMR-CAUGA2A-151A (Incremental:Separated interpolator unit (IPU) type)
NMR-CAUHA2A-151A (Absolute:Separated interpolator unit (IPU) type)

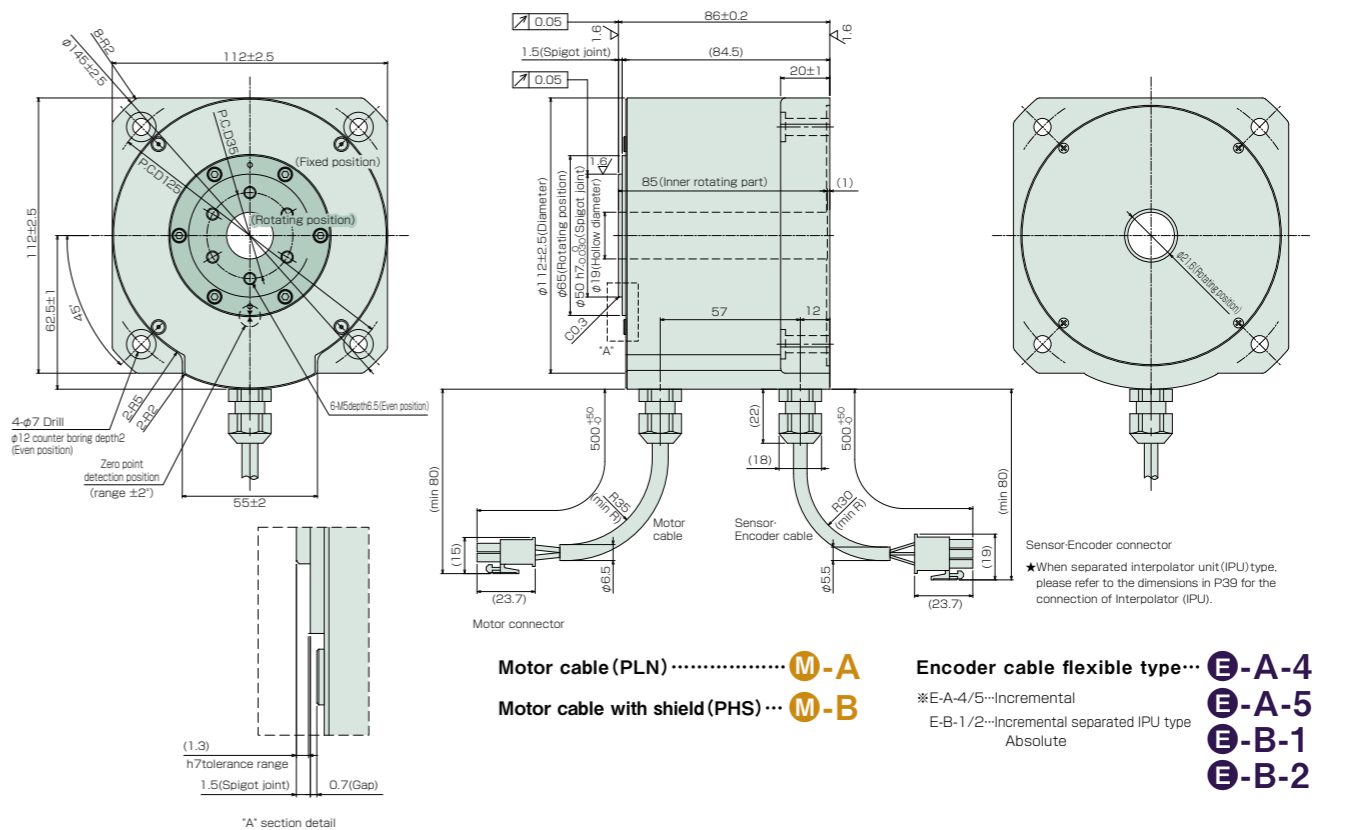

TDISC ND-c series dimensions

- ND140-70-LC NMR-CREIA2A-151A (Incremental)
- NMR-CREGA2A-151A (Incremental:Separated interpolator unit (IPU) type)
- NMR-CREHA2A-151A (Absolute:Separated interpolator unit (IPU) type)

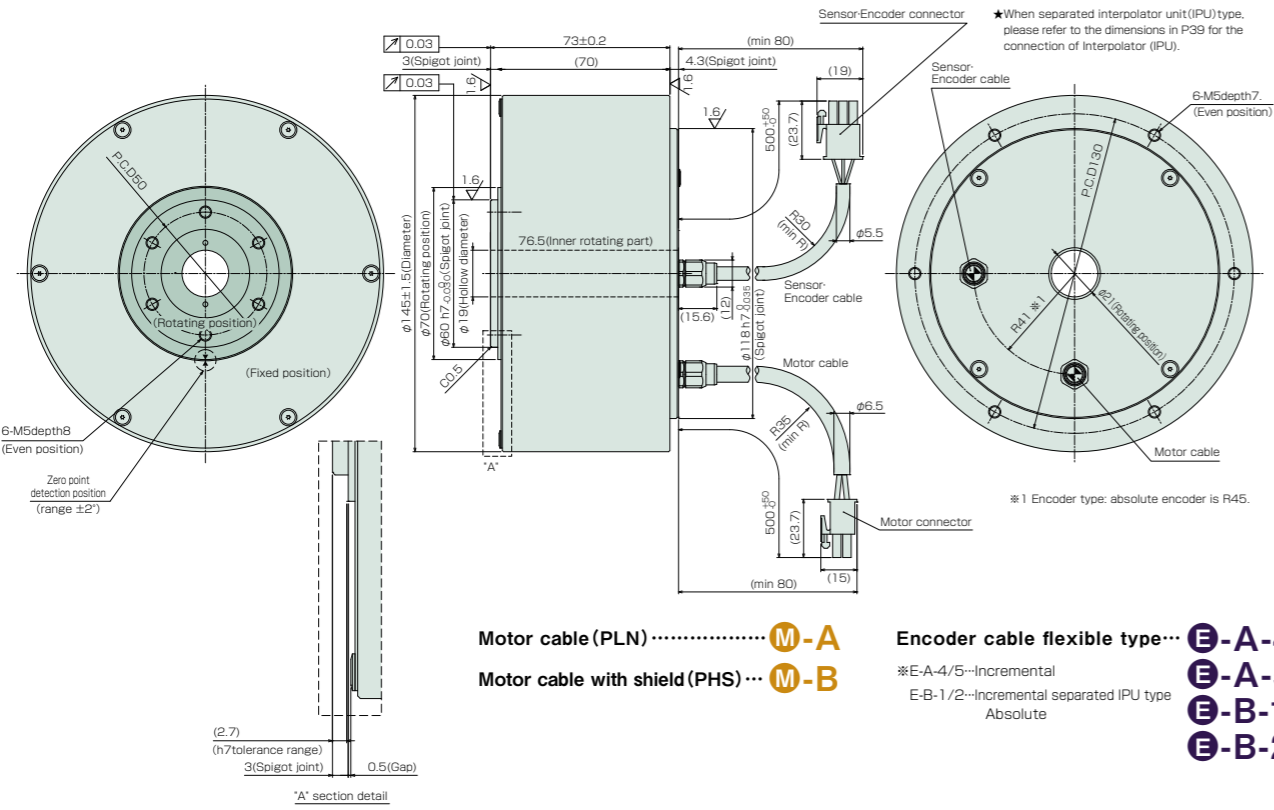

- ND140-95-LC NMR-CRFIA2A-311A (Incremental)
- NMR-CRFGA2A-311A (Incremental:Separated interpolator unit (IPU) type)
- NMR-CRFHA2A-311A (Absolute:Separated interpolator unit (IPU) type)

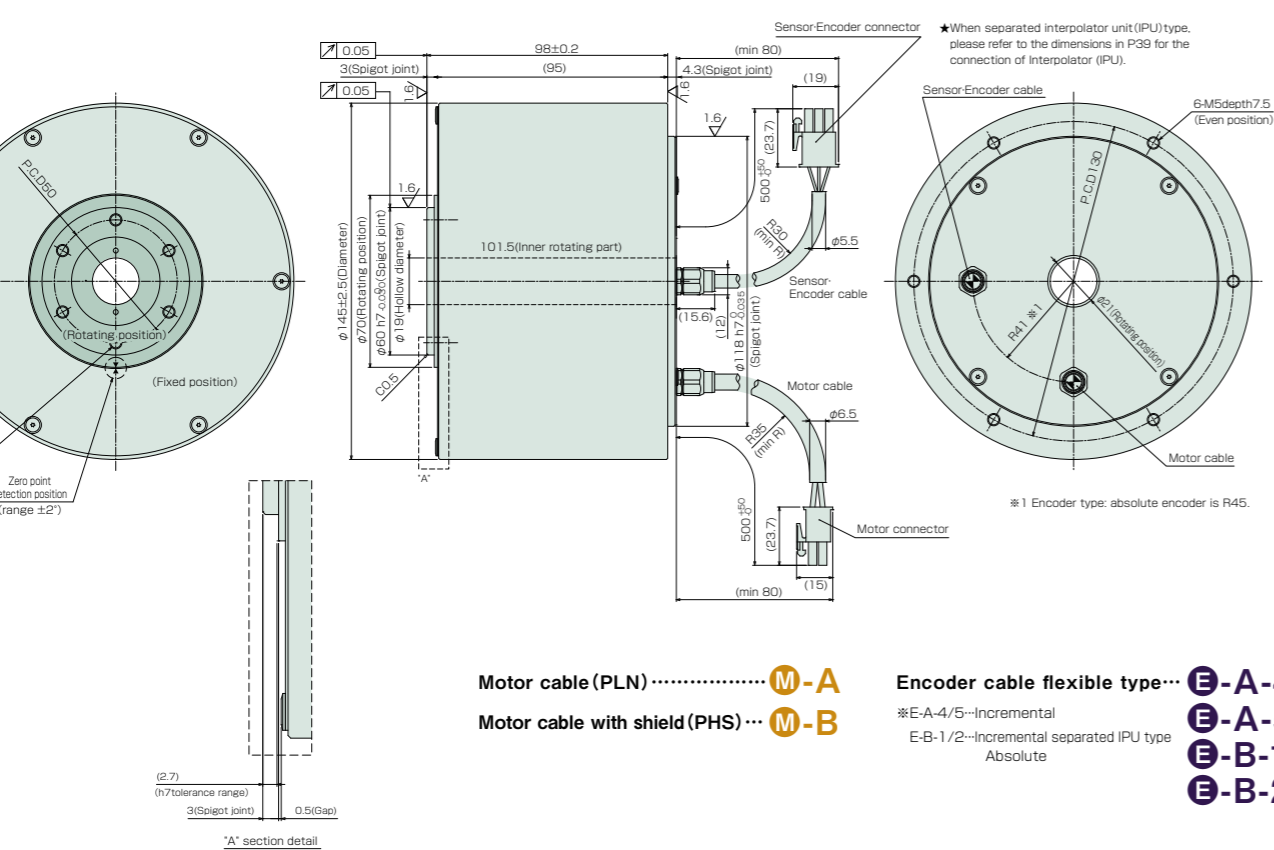

TDISC ND-c series dimensions

- ND180-70-LC NMR-CSMIA2A-281A (Incremental)
- NMR-CSMGA2A-281A (Incremental:Separated interpolator unit (IPU) type)
- NMR-CSMHA2A-281A (Absolute:Separated interpolator unit (IPU) type)

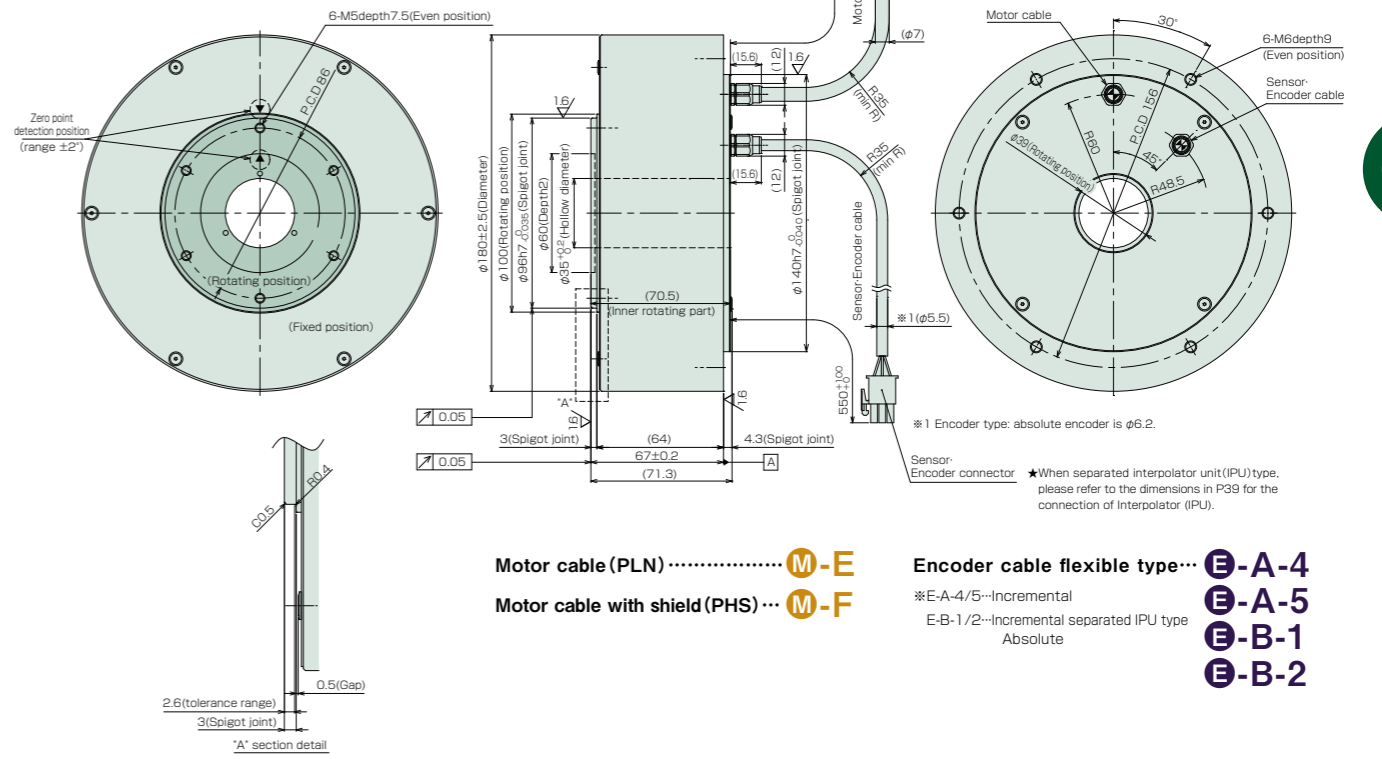

- ND180-95-LC NMR-CSEIA2A-561A (Incremental)
- NMR-CSEGA2A-561A (Incremental:Separated interpolator unit (IPU) type)
- NMR-CSEHA2A-561A (Absolute:Separated interpolator unit (IPU) type)

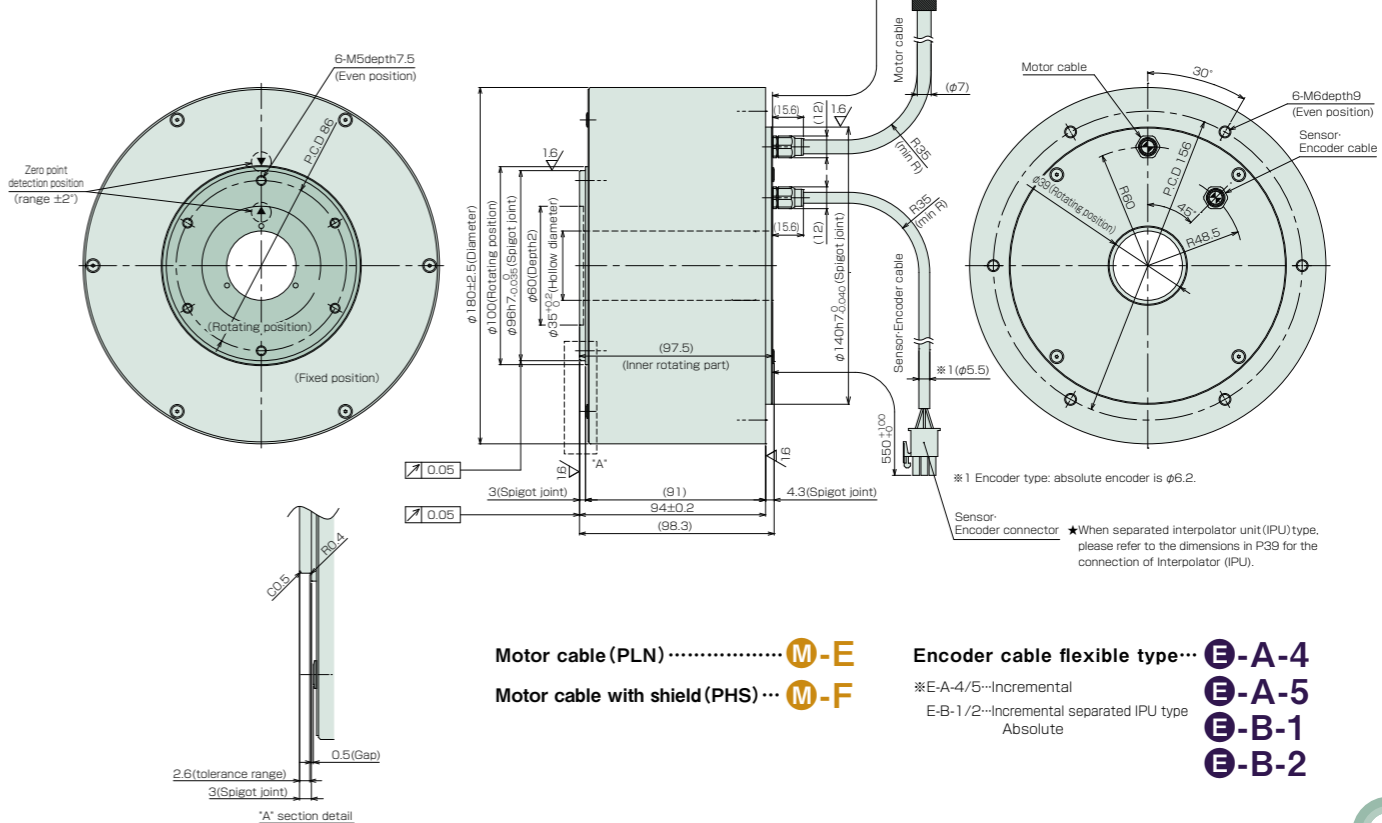

TDISC ND-c series dimensions

ND400-120-LC NMR-CUGHA2A-152A (1rps specification)
NMR-CUGHA2A-652A (4.16rps specification)

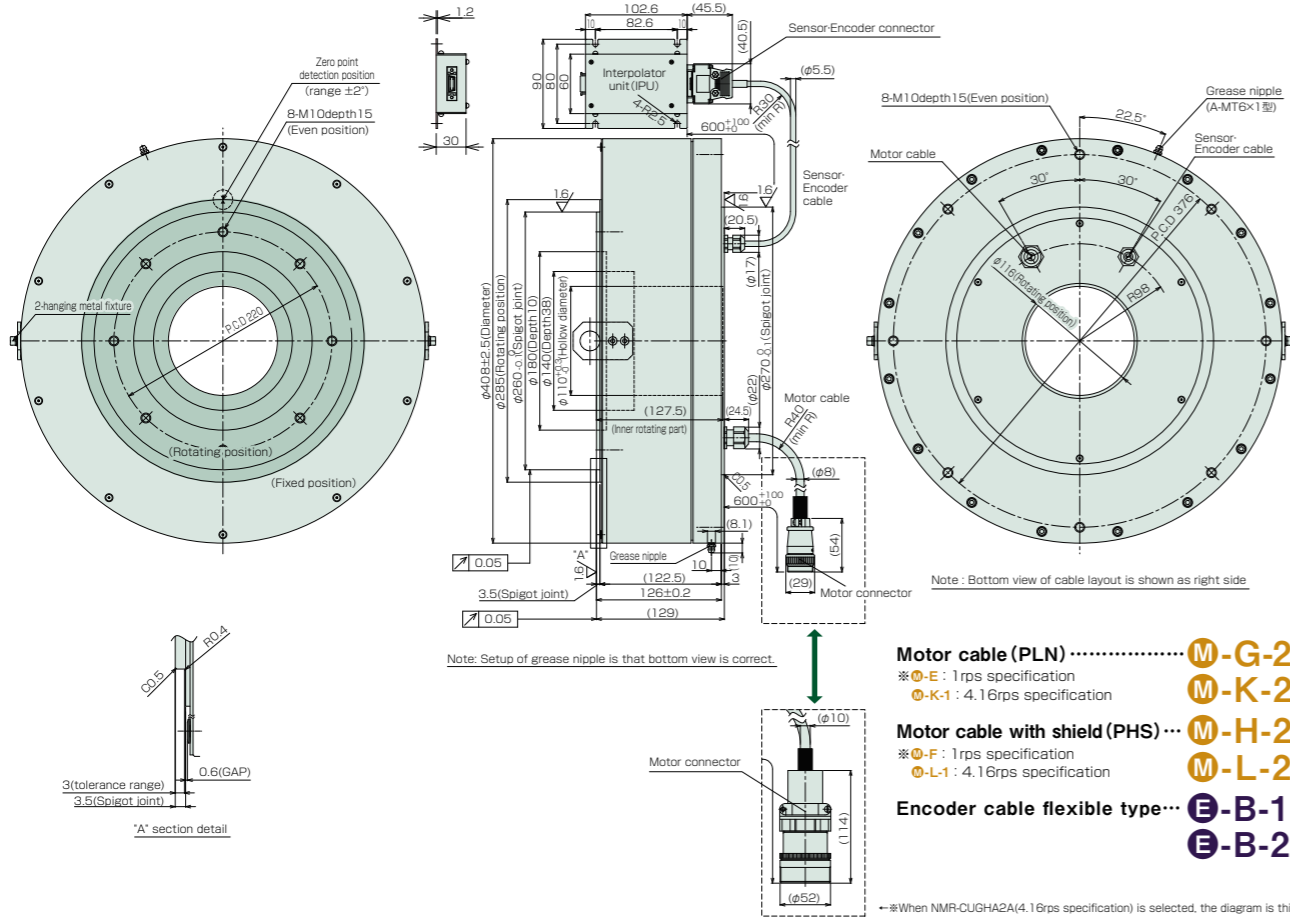

TDISC ND series dimensions

ND110-50-F
NMR-NAMBA2A-071A (Incremental)

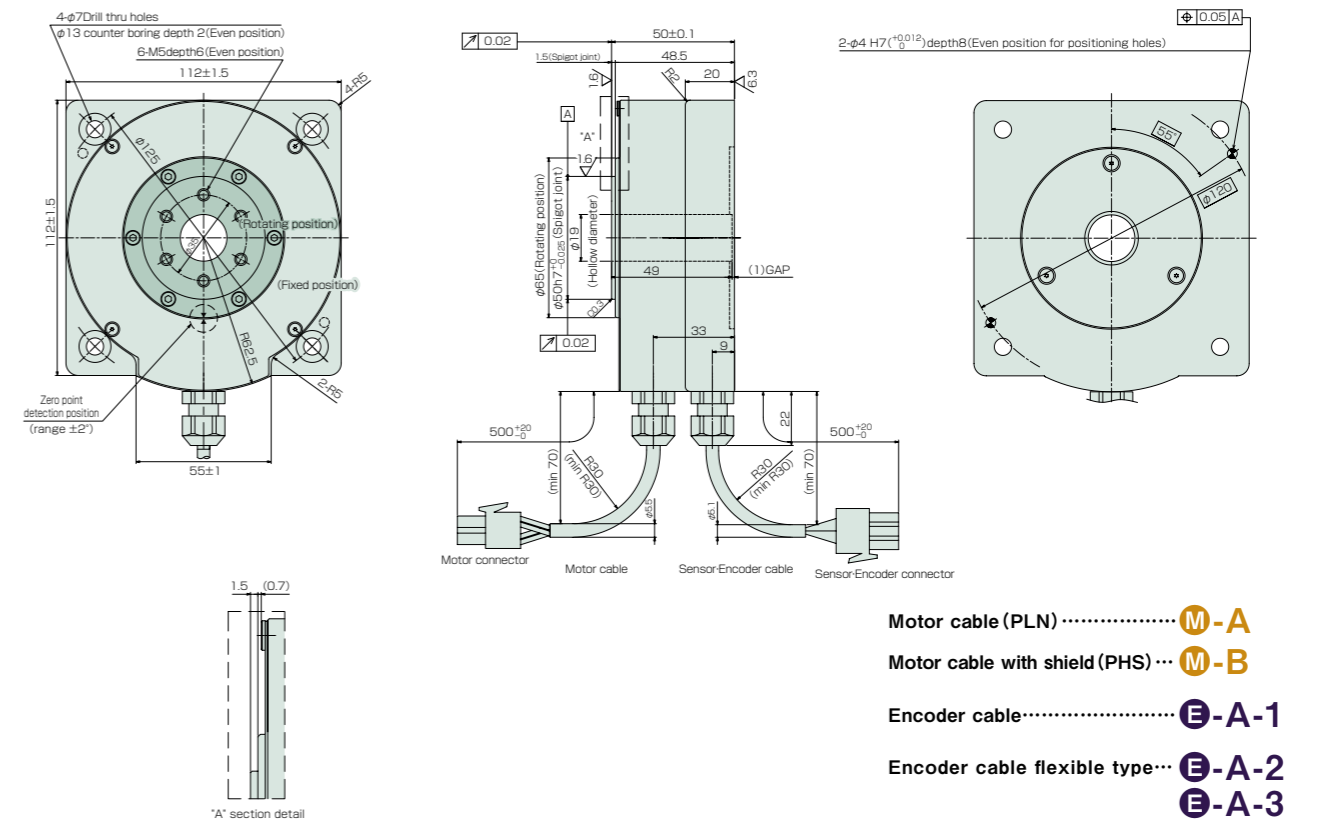

ND110-100-L
NMR-NPEBA2A-201A (Incremental)

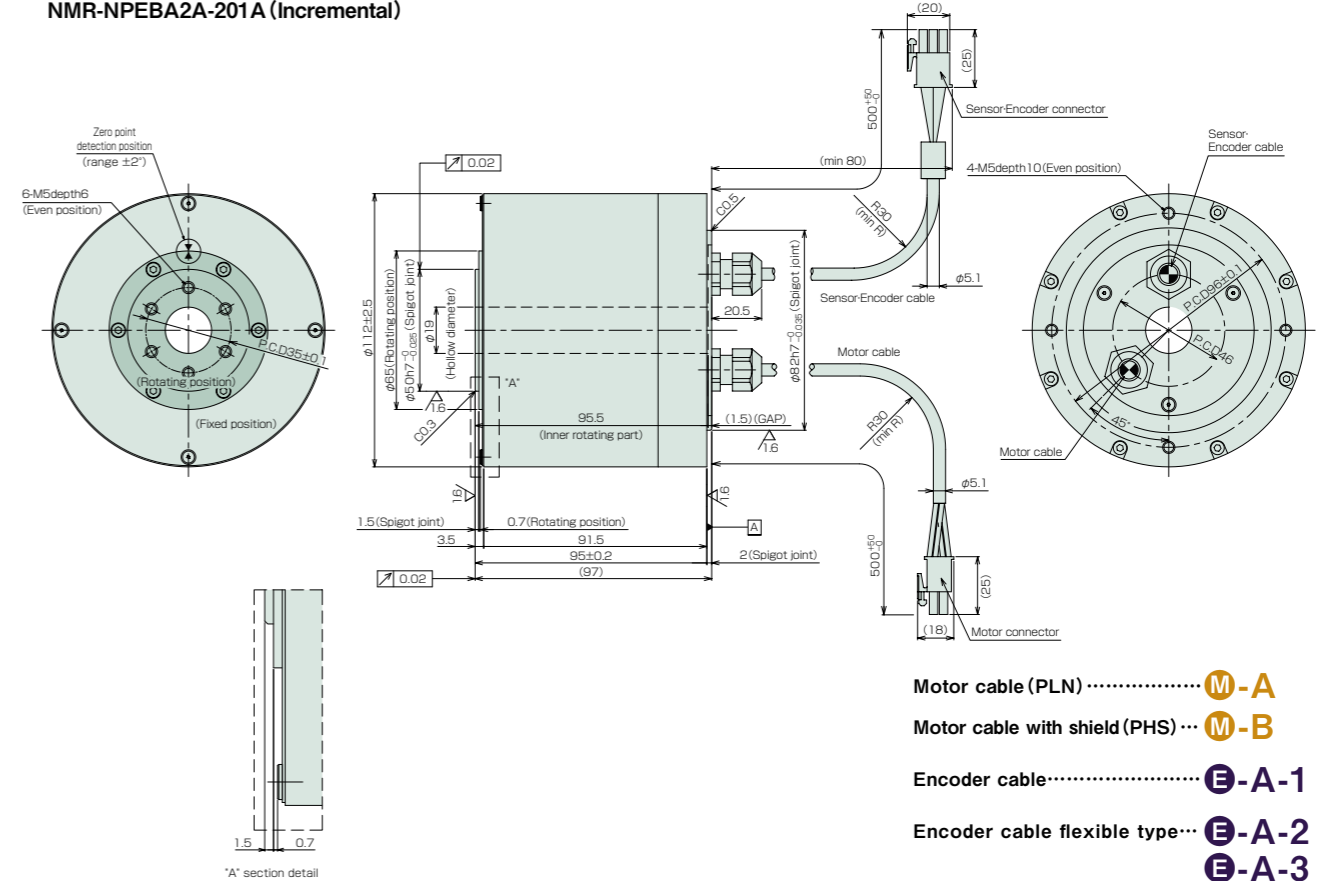

TDISC ND series dimensions

ND180-55-F
NMR-NDMGA2A-201A (Incremental)

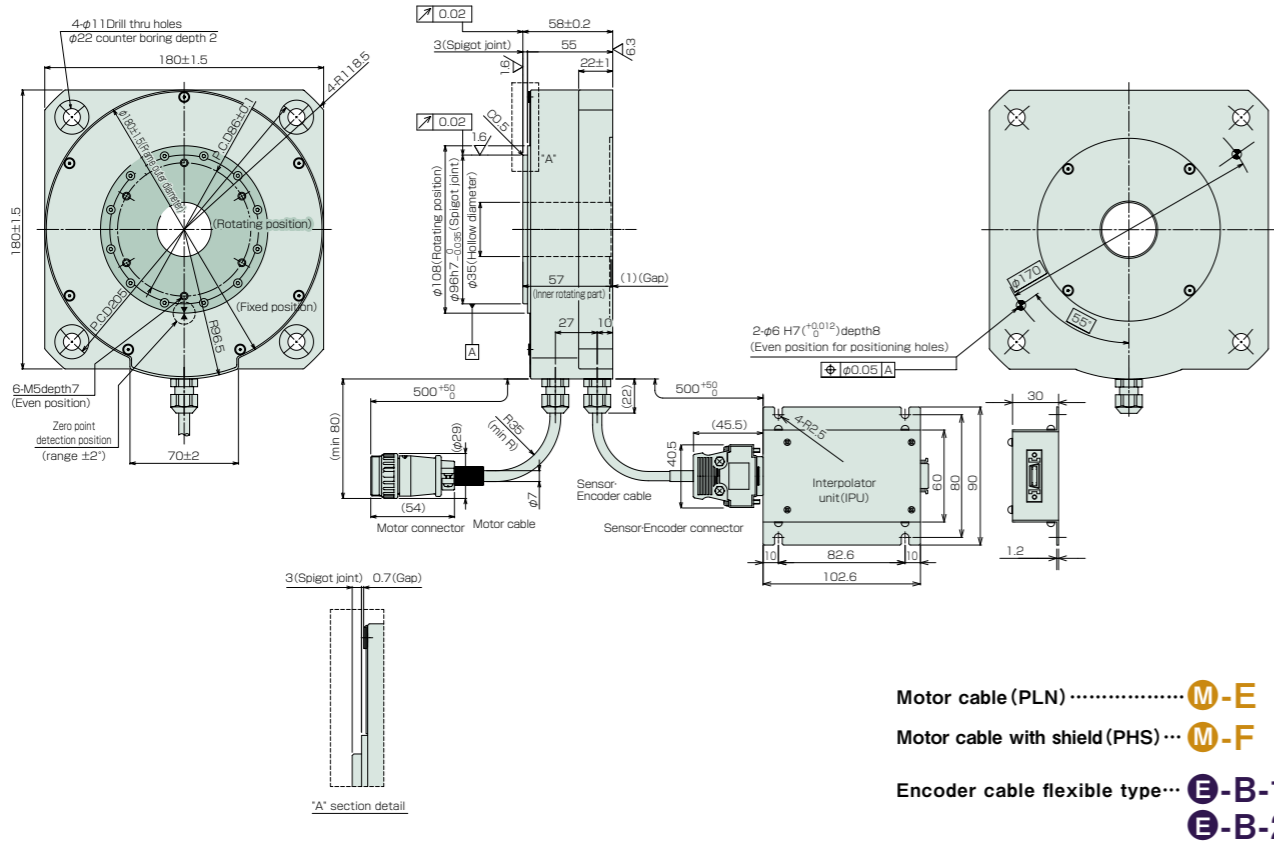

TDISC ND series dimensions

ND250-55-F
NMR-NEMGA2B-401A (Incremental)
NMR-NEMHA2B-401A (Absolute)

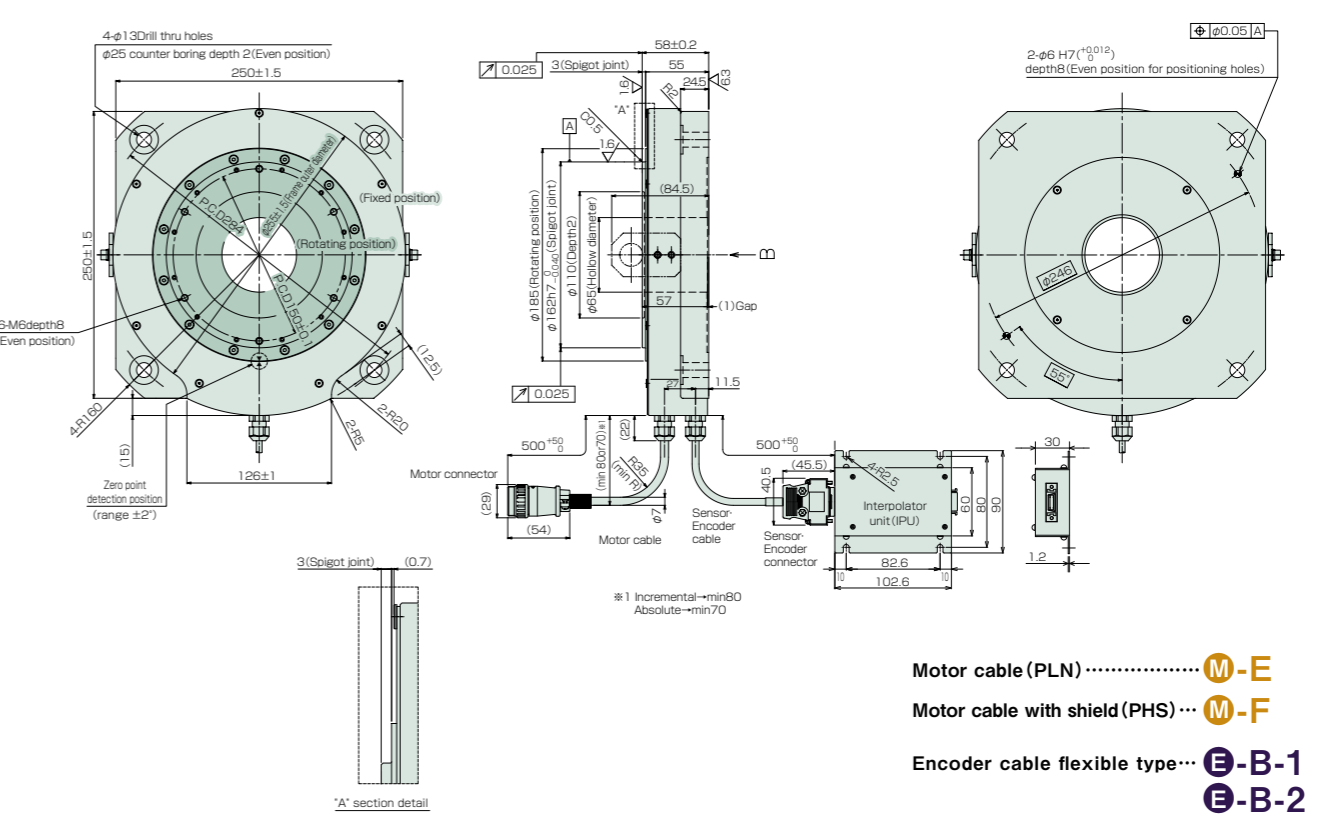

ND180-110-L
NMR-NSFGA2B-701A (Incremental)

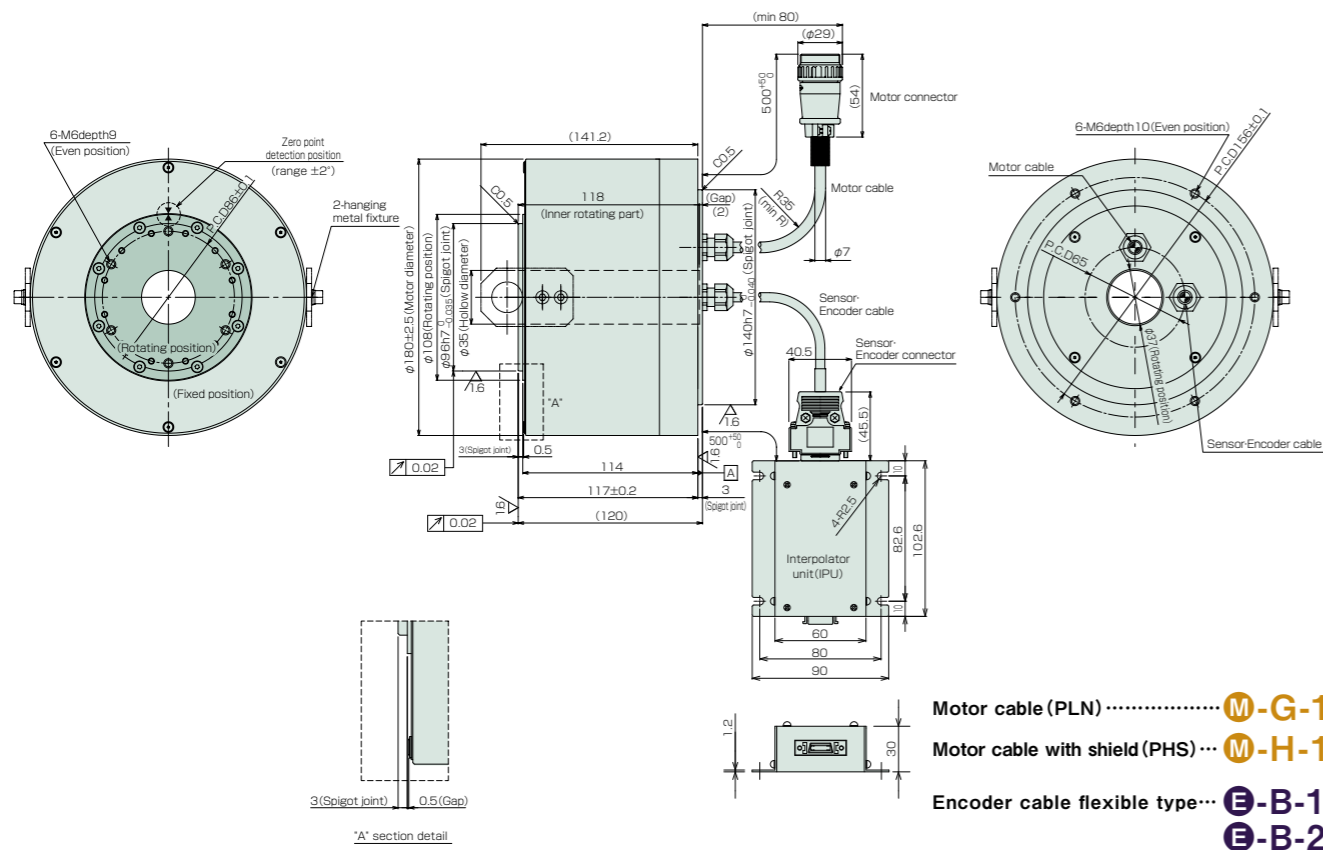

ND250-110-L
NMR-NTFGA2B-122A (Incremental)
NMR-NTFHA2B-122A (Absolute)

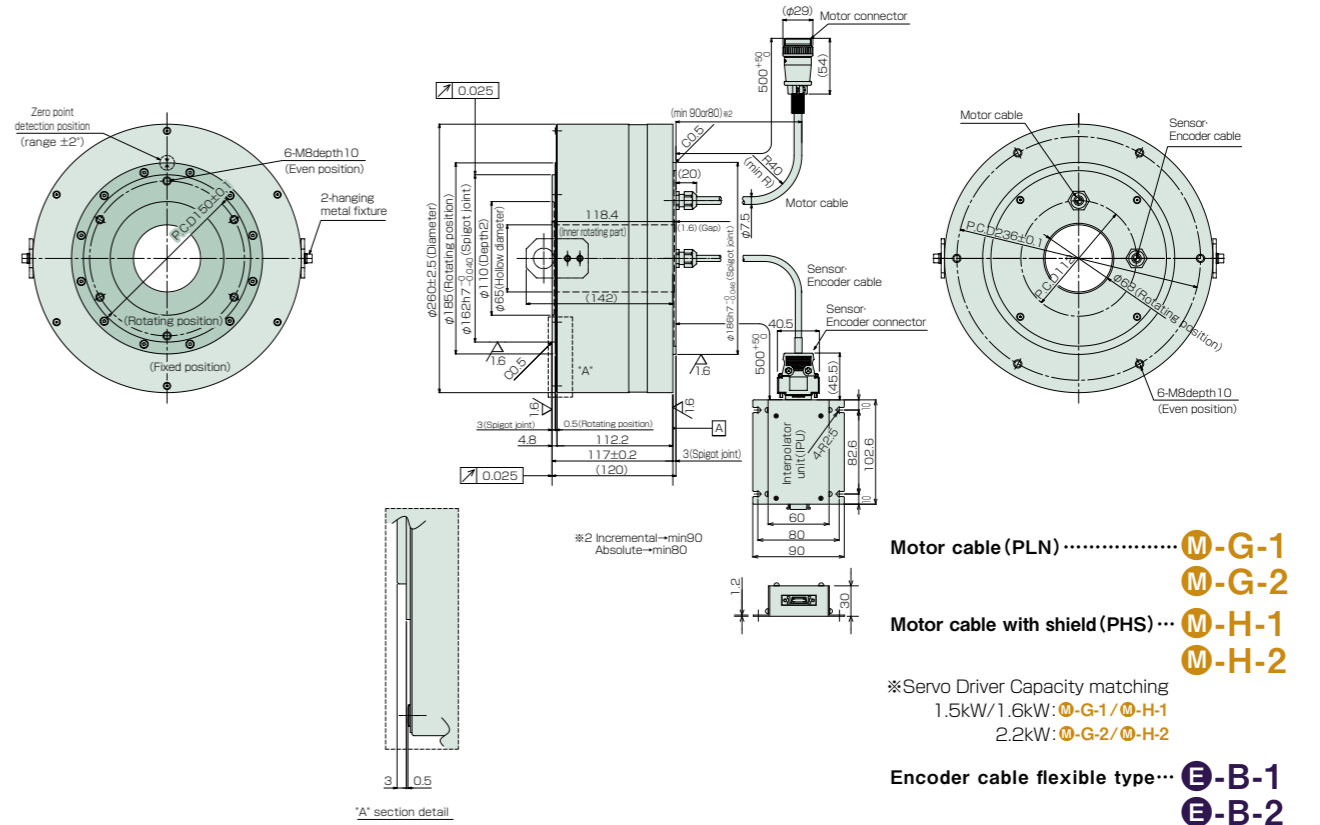

● T DISC ND series dimensions

○ ND400-55-F
NMR-NFMGA2B-801A (Incremental)
NMR-NFMHA2B-801A (Absolute)

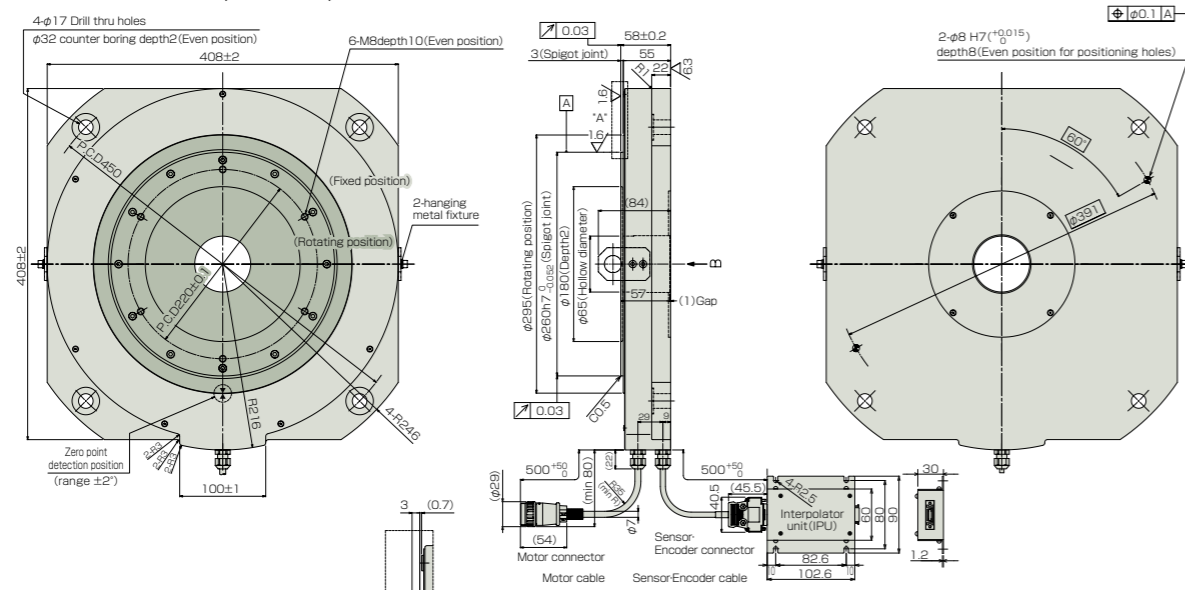

- Motor cable (PLN) M-E
- Motor cable with shield (PHS) ... M-F
- Encoder cable flexible type... E-B-1
E-B-2

○ ND400-110-L
NMR-NUFGA2B-252A (Incremental)
NMR-NUFHA2B-252A (Absolute)

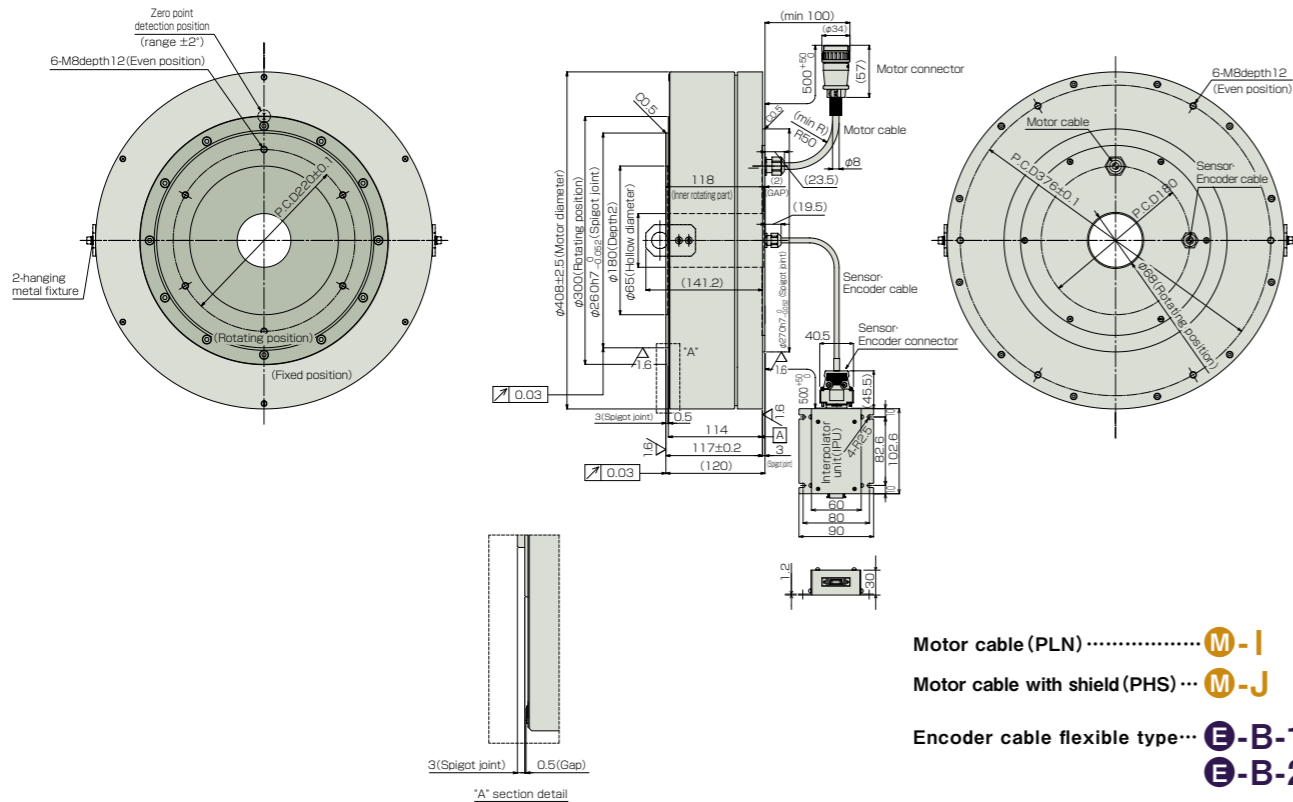

- Motor cable (PLN) M-I
- Motor cable with shield (PHS) ... M-J
- Encoder cable flexible type... E-B-1
E-B-2

● T DISC ND series dimensions

○ ND400-175-L
[1.5rps specification]
NMR-NUIGA2A-472AZ (Incremental) / NMR-NUIHA2A-472AZ (Absolute)
[3rps specification]
NMR-NUIGA2A-862AZ (Incremental) / NMR-NUIHA2A-862AZ (Absolute)

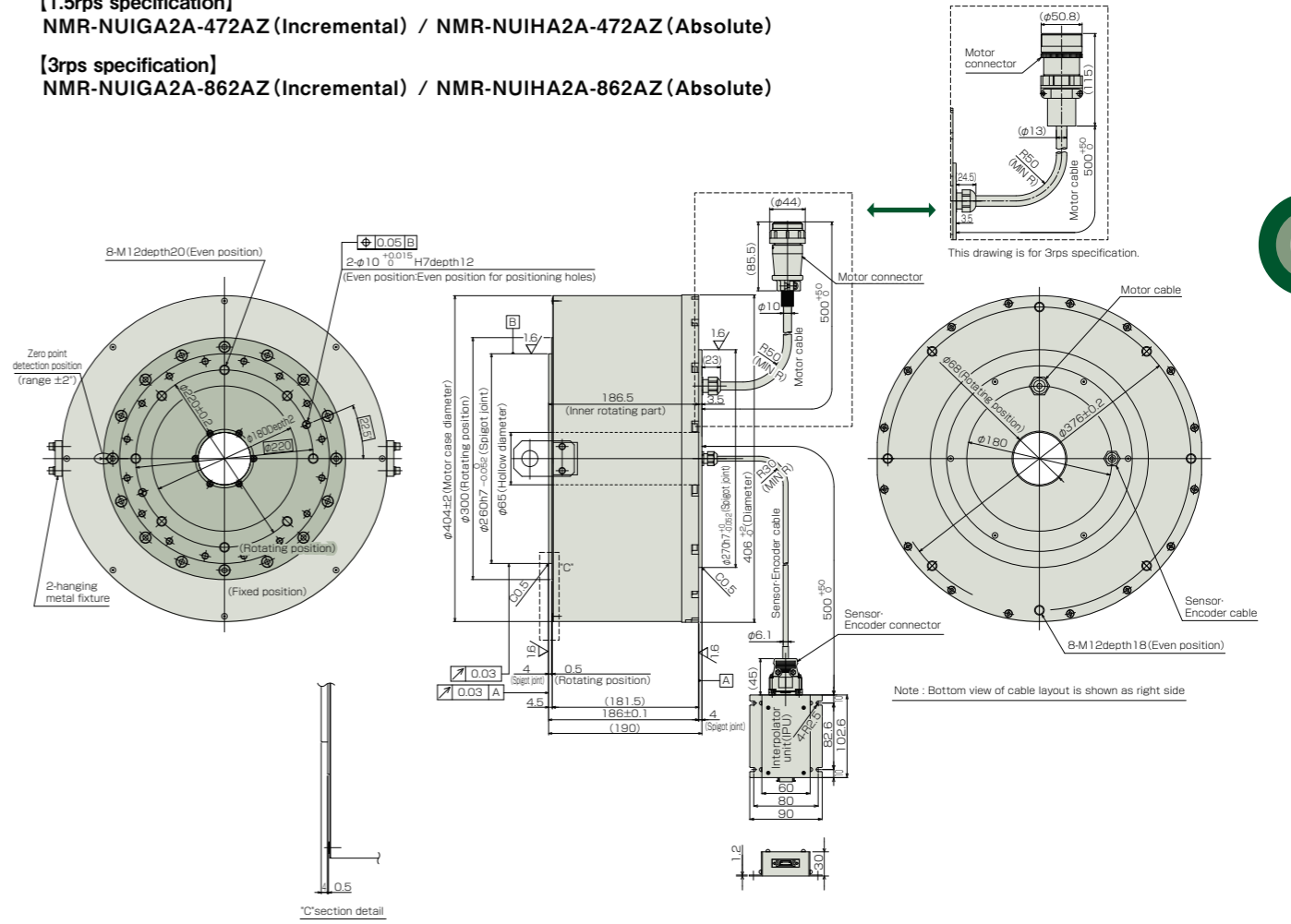

- Motor cable (PLN) M-M-1
* M-M-1 : 1.5rps specification
M-K-2 : 3rps specification
- Motor cable with shield (PHS) ... M-N-1
* M-N-1 : 1.5rps specification
M-L-2 : 3rps specification
- Encoder cable flexible type... E-B-1
E-B-2

● Interpolator unit (IPU)

If the external type interpolator is selected, please refer to the diagram for interpolator (IPU) setting.

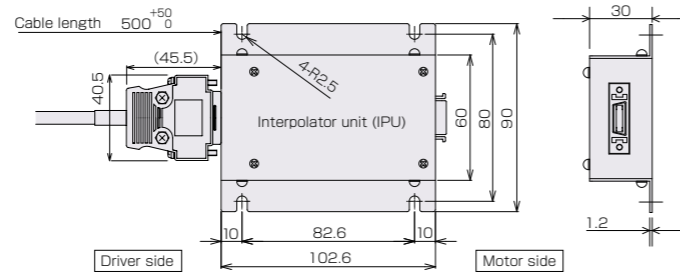

● Encoder cable connector kit

Motor type	Model No. Encoder connector kit
D110	ZCK-ENC
ND110	
ND-c (built-in Interpolator unit)	NCR-XBC8A
D170/D250/D400	
D400-175	NCR-XBDCA
D170/D250	
D630	NCR-XBDF A
D140	NCR-XBDMA

There is no lineup for connector kit of separated interpolator unit (IPU) type. Please order encoder cable (NCR-XBCLA***).

■ Driver side

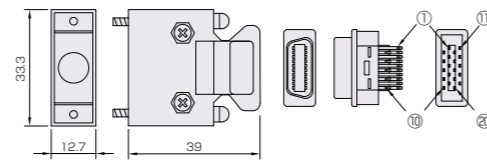

● External power supply unit

Model
NCR-XAD1A

NCR-XAD1A is external power supply unit for 30m specification of P40 **E-B-1**•**E-B-2**.

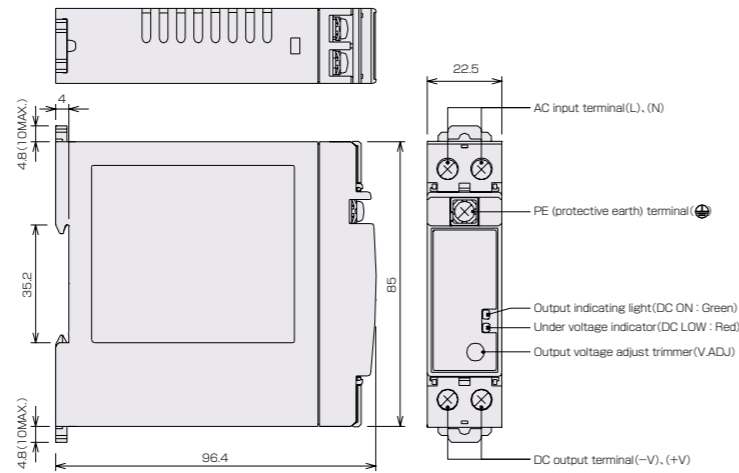

● Encoder cable reference chart

Encoder cable No.	Model	Length(L)	Encoder cable dimensions	Signal chart	Encoder connector (Motor side)																																																																																												
E-A-1	ZEC-030A	3m	<p>E-A-1/E-A-2 Twist pair sealed cable 0.5SQ×1P+0.2SQ×4P E-A-3 Twist pair sealed cable 0.5SQ×1P+0.2SQ×6P</p>	<table border="1"> <tr><th colspan="2">P1 (Driver side) signal list</th><th colspan="2">J1 (Encoder side) signal list</th></tr> <tr><th>Name of signal chart</th><th>Pin No.</th><th>Name of signal chart</th><th>Pin No.</th></tr> <tr><td>GND</td><td>1</td><td>B</td><td>1</td></tr> <tr><td>GND</td><td>2</td><td>B*</td><td>2</td></tr> <tr><td>+5V</td><td>3</td><td>A</td><td>3</td></tr> <tr><td>+5V</td><td>4</td><td>A*</td><td>4</td></tr> <tr><td></td><td>5</td><td>Z</td><td>5</td></tr> <tr><td></td><td>6</td><td>Z*</td><td>6</td></tr> <tr><td></td><td>7</td><td>+5V</td><td>7</td></tr> <tr><td>A</td><td>8</td><td>GND</td><td>8</td></tr> <tr><td>A*</td><td>9</td><td>FG (Ground)</td><td>9</td></tr> <tr><td>B</td><td>10</td><td></td><td></td></tr> <tr><td>B*</td><td>11</td><td></td><td></td></tr> <tr><td>Z</td><td>12</td><td></td><td></td></tr> <tr><td>Z*</td><td>13</td><td></td><td></td></tr> <tr><td></td><td>14</td><td></td><td></td></tr> <tr><td></td><td>15</td><td></td><td></td></tr> <tr><td></td><td>16</td><td></td><td></td></tr> <tr><td>RX</td><td>17</td><td></td><td></td></tr> <tr><td>RX*</td><td>18</td><td></td><td></td></tr> <tr><td></td><td>19</td><td></td><td></td></tr> <tr><td>FG (Ground)</td><td>20</td><td></td><td></td></tr> <tr><td>FG (Ground)</td><td>Metal</td><td></td><td></td></tr> </table>	P1 (Driver side) signal list		J1 (Encoder side) signal list		Name of signal chart	Pin No.	Name of signal chart	Pin No.	GND	1	B	1	GND	2	B*	2	+5V	3	A	3	+5V	4	A*	4		5	Z	5		6	Z*	6		7	+5V	7	A	8	GND	8	A*	9	FG (Ground)	9	B	10			B*	11			Z	12			Z*	13				14				15				16			RX	17			RX*	18				19			FG (Ground)	20			FG (Ground)	Metal			<p>ZCK-ENC</p>
	P1 (Driver side) signal list				J1 (Encoder side) signal list																																																																																												
	Name of signal chart	Pin No.			Name of signal chart	Pin No.																																																																																											
	GND	1			B	1																																																																																											
	GND	2			B*	2																																																																																											
+5V	3	A	3																																																																																														
+5V	4	A*	4																																																																																														
	5	Z	5																																																																																														
	6	Z*	6																																																																																														
	7	+5V	7																																																																																														
A	8	GND	8																																																																																														
A*	9	FG (Ground)	9																																																																																														
B	10																																																																																																
B*	11																																																																																																
Z	12																																																																																																
Z*	13																																																																																																
	14																																																																																																
	15																																																																																																
	16																																																																																																
RX	17																																																																																																
RX*	18																																																																																																
	19																																																																																																
FG (Ground)	20																																																																																																
FG (Ground)	Metal																																																																																																
E-A-2	ZRC-030A	3m																																																																																															
	-050A	5m																																																																																															
	-100A	10m																																																																																															
	-150A	15m																																																																																															
	-200A	20m																																																																																															
E-A-3	ZRC-300A	30m																																																																																															
E-A-4	NCR-XBCNA-030	3m	<p>E-A-4 Twist pair sealed cable 0.5SQ×1P+0.2SQ×6P E-A-5 Twist pair sealed cable 1.25SQ×1P+0.2SQ×5P</p>	<table border="1"> <tr><th colspan="2">P1 (Driver side) signal list</th><th colspan="2">J1 (Encoder side) signal list</th></tr> <tr><th>Name of signal chart</th><th>Pin No.</th><th>Name of signal chart</th><th>Pin No.</th></tr> <tr><td>GND</td><td>1</td><td>B</td><td>1</td></tr> <tr><td>GND</td><td>2</td><td>B*</td><td>2</td></tr> <tr><td>+5V</td><td>3</td><td>A</td><td>3</td></tr> <tr><td>+5V</td><td>4</td><td>A*</td><td>4</td></tr> <tr><td></td><td>5</td><td>Z</td><td>5</td></tr> <tr><td></td><td>6</td><td>Z*</td><td>6</td></tr> <tr><td></td><td>7</td><td>PS</td><td>7</td></tr> <tr><td>A</td><td>8</td><td>PS*</td><td>8</td></tr> <tr><td>B</td><td>9</td><td>PC</td><td>9</td></tr> <tr><td>B*</td><td>10</td><td>PC*</td><td>10</td></tr> <tr><td>Z</td><td>11</td><td>+5V</td><td>11</td></tr> <tr><td>Z*</td><td>12</td><td>GND</td><td>12</td></tr> <tr><td></td><td>13</td><td>+5V</td><td>13</td></tr> <tr><td>PS*</td><td>14</td><td>GND</td><td>14</td></tr> <tr><td>PC</td><td>15</td><td>FG (Ground)</td><td>15</td></tr> <tr><td>PC*</td><td>16</td><td></td><td></td></tr> <tr><td></td><td>17</td><td></td><td></td></tr> <tr><td></td><td>18</td><td></td><td></td></tr> <tr><td></td><td>19</td><td></td><td></td></tr> <tr><td>FG (Ground)</td><td>20</td><td></td><td></td></tr> <tr><td>FG (Ground)</td><td>Metal</td><td></td><td></td></tr> </table>	P1 (Driver side) signal list		J1 (Encoder side) signal list		Name of signal chart	Pin No.	Name of signal chart	Pin No.	GND	1	B	1	GND	2	B*	2	+5V	3	A	3	+5V	4	A*	4		5	Z	5		6	Z*	6		7	PS	7	A	8	PS*	8	B	9	PC	9	B*	10	PC*	10	Z	11	+5V	11	Z*	12	GND	12		13	+5V	13	PS*	14	GND	14	PC	15	FG (Ground)	15	PC*	16				17				18				19			FG (Ground)	20			FG (Ground)	Metal			<p>NCR-XBC8A</p>
	P1 (Driver side) signal list				J1 (Encoder side) signal list																																																																																												
	Name of signal chart	Pin No.			Name of signal chart	Pin No.																																																																																											
GND	1	B	1																																																																																														
GND	2	B*	2																																																																																														
+5V	3	A	3																																																																																														
+5V	4	A*	4																																																																																														
	5	Z	5																																																																																														
	6	Z*	6																																																																																														
	7	PS	7																																																																																														
A	8	PS*	8																																																																																														
B	9	PC	9																																																																																														
B*	10	PC*	10																																																																																														
Z	11	+5V	11																																																																																														
Z*	12	GND	12																																																																																														
	13	+5V	13																																																																																														
PS*	14	GND	14																																																																																														
PC	15	FG (Ground)	15																																																																																														
PC*	16																																																																																																
	17																																																																																																
	18																																																																																																
	19																																																																																																
FG (Ground)	20																																																																																																
FG (Ground)	Metal																																																																																																
E-A-5	NCR-XBCNA-200	20m																																																																																															
	-300	30m																																																																																															
E-B-1	NCR-XBCLA-030	3m	<p>E-B-1 Robot encoder cable 0.5SQ×1P+0.2SQ×4P E-B-2 Robot encoder cable 0.5SQ×1P+0.2SQ×6P</p>	<table border="1"> <tr><th colspan="2">P1 (Driver side) signal list</th><th colspan="2">J1 (Encoder side) signal list</th></tr> <tr><th>Name of signal chart</th><th>Pin No.</th><th>Name of signal chart</th><th>Pin No.</th></tr> <tr><td>GND</td><td>1</td><td>GND</td><td>1</td></tr> <tr><td>GND</td><td>2</td><td>GND</td><td>2</td></tr> <tr><td>+5V</td><td>3</td><td>+5V</td><td>3</td></tr> <tr><td>+5V</td><td>4</td><td>+5V</td><td>4</td></tr> <tr><td>SD</td><td>5</td><td>SD</td><td>5</td></tr> <tr><td>SD*</td><td>6</td><td>SD*</td><td>6</td></tr> <tr><td></td><td>7</td><td></td><td></td></tr> <tr><td></td><td>8</td><td></td><td></td></tr> <tr><td></td><td>9</td><td></td><td></td></tr> <tr><td></td><td>10</td><td></td><td></td></tr> <tr><td></td><td>11</td><td></td><td></td></tr> <tr><td>Z</td><td>12</td><td>Z</td><td>12</td></tr> <tr><td>Z*</td><td>13</td><td>Z*</td><td>13</td></tr> <tr><td></td><td>14</td><td></td><td></td></tr> <tr><td></td><td>15</td><td></td><td></td></tr> <tr><td></td><td>16</td><td></td><td></td></tr> <tr><td></td><td>17</td><td></td><td></td></tr> <tr><td></td><td>18</td><td></td><td></td></tr> <tr><td></td><td>19</td><td></td><td></td></tr> <tr><td>FG (Ground)</td><td>20</td><td>FG (Ground)</td><td>20</td></tr> <tr><td>FG (Ground)</td><td>Metal</td><td>FG (Ground)</td><td>Metal</td></tr> </table>	P1 (Driver side) signal list		J1 (Encoder side) signal list		Name of signal chart	Pin No.	Name of signal chart	Pin No.	GND	1	GND	1	GND	2	GND	2	+5V	3	+5V	3	+5V	4	+5V	4	SD	5	SD	5	SD*	6	SD*	6		7				8				9				10				11			Z	12	Z	12	Z*	13	Z*	13		14				15				16				17				18				19			FG (Ground)	20	FG (Ground)	20	FG (Ground)	Metal	FG (Ground)	Metal	<p>NCR-XBDCA</p>
	P1 (Driver side) signal list				J1 (Encoder side) signal list																																																																																												
	Name of signal chart	Pin No.			Name of signal chart	Pin No.																																																																																											
GND	1	GND	1																																																																																														
GND	2	GND	2																																																																																														
+5V	3	+5V	3																																																																																														
+5V	4	+5V	4																																																																																														
SD	5	SD	5																																																																																														
SD*	6	SD*	6																																																																																														
	7																																																																																																
	8																																																																																																
	9																																																																																																
	10																																																																																																
	11																																																																																																
Z	12	Z	12																																																																																														
Z*	13	Z*	13																																																																																														
	14																																																																																																
	15																																																																																																
	16																																																																																																
	17																																																																																																
	18																																																																																																
	19																																																																																																
FG (Ground)	20	FG (Ground)	20																																																																																														
FG (Ground)	Metal	FG (Ground)	Metal																																																																																														
E-B-2	NCR-XBCLA-150	15m																																																																																															
	-200	20m																																																																																															
	-300-Z*	30m	<p>*For using 30m cable, the external DC5V power is required. P39 NCR-XAD1A type are available as an option.</p>																																																																																														
E-C-1	NCR-XBCOA-030	3m	<p>E-C-1 Twist pair sealed cable 0.5SQ×1P+0.2SQ×6P E-C-2 Twist pair sealed cable 1.25SQ×1P+0.2SQ×5P</p>	<table border="1"> <tr><th colspan="2">P1 (Driver side) signal list</th><th colspan="2">J1 (Encoder side) signal list</th></tr> <tr><th>Name of signal chart</th><th>Pin No.</th><th>Name of signal chart</th><th>Pin No.</th></tr> <tr><td>GND</td><td>1</td><td>B</td><td>1</td></tr> <tr><td>GND</td><td>2</td><td>B*</td><td>2</td></tr> <tr><td>+5V</td><td>3</td><td>A</td><td>3</td></tr> <tr><td>+5V</td><td>4</td><td>A*</td><td>4</td></tr> <tr><td></td><td>5</td><td>Z</td><td>5</td></tr> <tr><td></td><td>6</td><td>Z*</td><td>6</td></tr> <tr><td></td><td>7</td><td>PS</td><td>7</td></tr> <tr><td>A*</td><td>8</td><td>PS*</td><td>8</td></tr> <tr><td>B</td><td>9</td><td>PC</td><td>9</td></tr> <tr><td>B*</td><td>10</td><td>PC*</td><td>10</td></tr> <tr><td>Z</td><td>11</td><td>+5V</td><td>11</td></tr> <tr><td>Z*</td><td>12</td><td>GND</td><td>12</td></tr> <tr><td>PS</td><td>13</td><td>+5V</td><td>13</td></tr> <tr><td>PS*</td><td>14</td><td>GND</td><td>14</td></tr> <tr><td>PC</td><td>15</td><td>FG (Ground)</td><td>15</td></tr> <tr><td>PC*</td><td>16</td><td></td><td></td></tr> <tr><td></td><td>17</td><td></td><td></td></tr> <tr><td></td><td>18</td><td></td><td></td></tr> <tr><td></td><td>19</td><td></td><td></td></tr> <tr><td>FG (Ground)</td><td>20</td><td>FG (Ground)</td><td>20</td></tr> <tr><td>FG (Ground)</td><td>Metal</td><td>FG (Ground)</td><td>Metal</td></tr> </table>	P1 (Driver side) signal list		J1 (Encoder side) signal list		Name of signal chart	Pin No.	Name of signal chart	Pin No.	GND	1	B	1	GND	2	B*	2	+5V	3	A	3	+5V	4	A*	4		5	Z	5		6	Z*	6		7	PS	7	A*	8	PS*	8	B	9	PC	9	B*	10	PC*	10	Z	11	+5V	11	Z*	12	GND	12	PS	13	+5V	13	PS*	14	GND	14	PC	15	FG (Ground)	15	PC*	16				17				18				19			FG (Ground)	20	FG (Ground)	20	FG (Ground)	Metal	FG (Ground)	Metal	<p>NCR-XBDFA</p>
	P1 (Driver side) signal list				J1 (Encoder side) signal list																																																																																												
	Name of signal chart	Pin No.			Name of signal chart	Pin No.																																																																																											
GND	1	B	1																																																																																														
GND	2	B*	2																																																																																														
+5V	3	A	3																																																																																														
+5V	4	A*	4																																																																																														
	5	Z	5																																																																																														
	6	Z*	6																																																																																														
	7	PS	7																																																																																														
A*	8	PS*	8																																																																																														
B	9	PC	9																																																																																														
B*	10	PC*	10																																																																																														
Z	11	+5V	11																																																																																														
Z*	12	GND	12																																																																																														
PS	13	+5V	13																																																																																														
PS*	14	GND	14																																																																																														
PC	15	FG (Ground)	15																																																																																														
PC*	16																																																																																																
	17																																																																																																
	18																																																																																																
	19																																																																																																
FG (Ground)	20	FG (Ground)	20																																																																																														
FG (Ground)	Metal	FG (Ground)	Metal																																																																																														
E-C-2	NCR-XBCOA-200	20m																																																																																															
	-300	30m																																																																																															
E-D-1	NCR-XBCRA-030	3m	<p>E-D-1 Twist pair sealed cable 0.5SQ×1P+0.2SQ×6P E-D-2 Twist pair sealed cable 1.25SQ×1P+0.2SQ×5P</p>	<table border="1"> <tr><th colspan="2">P1 (Driver side) signal list</th><th colspan="2">J1 (Encoder side) signal list</th></tr> <tr><th>Name of signal chart</th><th>Pin No.</th><th>Name of signal chart</th><th>Pin No.</th></tr> <tr><td>GND</td><td>1</td><td>A</td><td>C</td></tr> <tr><td>GND</td><td>2</td><td>A*</td><td>D</td></tr> <tr><td>+5V</td><td>3</td><td>B</td><td>A</td></tr> <tr><td>+5V</td><td>4</td><td>B*</td><td>B</td></tr> <tr><td></td><td>5</td><td>Z</td><td>E</td></tr> <tr><td></td><td>6</td><td>Z*</td><td>F</td></tr> <tr><td>A</td><td>7</td><td>PS</td><td>G</td></tr> <tr><td>A*</td><td>8</td><td>PS*</td><td>H</td></tr> <tr><td>B</td><td>9</td><td>PC</td><td>J</td></tr> <tr><td>B*</td><td>10</td><td>PC*</td><td>K</td></tr> <tr><td>Z</td><td>11</td><td>+5V</td><td>L</td></tr> <tr><td>Z*</td><td>12</td><td>GND</td><td>M</td></tr> <tr><td>PS</td><td>13</td><td>+5V</td><td>N</td></tr> <tr><td>PS*</td><td>14</td><td>GND</td><td>P</td></tr> <tr><td>PC</td><td>15</td><td>FG (Ground)</td><td>R</td></tr> <tr><td>PC*</td><td>16</td><td></td><td></td></tr> <tr><td></td><td>17</td><td></td><td></td></tr> <tr><td></td><td>18</td><td></td><td></td></tr> <tr><td></td><td>19</td><td></td><td></td></tr> <tr><td>FG (Ground)</td><td>20</td><td></td><td></td></tr> <tr><td>FG (Ground)</td><td>Metal</td><td></td><td></td></tr> </table>	P1 (Driver side) signal list		J1 (Encoder side) signal list		Name of signal chart	Pin No.	Name of signal chart	Pin No.	GND	1	A	C	GND	2	A*	D	+5V	3	B	A	+5V	4	B*	B		5	Z	E		6	Z*	F	A	7	PS	G	A*	8	PS*	H	B	9	PC	J	B*	10	PC*	K	Z	11	+5V	L	Z*	12	GND	M	PS	13	+5V	N	PS*	14	GND	P	PC	15	FG (Ground)	R	PC*	16				17				18				19			FG (Ground)	20			FG (Ground)	Metal			<p>NCR-XBDMA</p>
	P1 (Driver side) signal list				J1 (Encoder side) signal list																																																																																												
	Name of signal chart	Pin No.			Name of signal chart	Pin No.																																																																																											
GND	1	A	C																																																																																														
GND	2	A*	D																																																																																														
+5V	3	B	A																																																																																														
+5V	4	B*	B																																																																																														
	5	Z	E																																																																																														
	6	Z*	F																																																																																														
A	7	PS	G																																																																																														
A*	8	PS*	H																																																																																														
B	9	PC	J																																																																																														
B*	10	PC*	K																																																																																														
Z	11	+5V	L																																																																																														
Z*	12	GND	M																																																																																														
PS	13	+5V	N																																																																																														
PS*	14	GND	P																																																																																														
PC	15	FG (Ground)	R																																																																																														
PC*	16																																																																																																
	17																																																																																																
	18																																																																																																
	19																																																																																																
FG (Ground)	20																																																																																																
FG (Ground)	Metal																																																																																																
E-D-2	NCR-XBCRA-200	20m																																																																																															
	-300	30m																																																																																															
E-E-1	NCR-XBCUA-030	3m	<p>E-E-1 Robot encoder cable 0.5SQ×1P+0.2SQ×4P E-E-2 Robot encoder cable 1.25SQ×1P+0.2SQ×5P</p>	<table border="1"> <tr><th colspan="2">P1 (Driver side) signal list</th><th colspan="2">J1 (Encoder side) signal list</th></tr> <tr><th>Name of signal chart</th><th>Pin No.</th><th>Name of signal chart</th><th>Pin No.</th></tr> <tr><td>GND</td><td>2</td><td>A*</td><td>6</td></tr> <tr><td>+5V</td><td>3</td><td>B</td><td>13</td></tr> <tr><td>+5V</td><td>4</td><td>B*</td><td>5</td></tr> <tr><td></td><td>5</td><td>Z</td><td>12</td></tr> <tr><td></td><td>6</td><td>Z*</td><td>4</td></tr> <tr><td>A</td><td>7</td><td>+5V</td><td>8</td></tr> <tr><td>A*</td><td>8</td><td>GND</td><td>9</td></tr> <tr><td>B</td><td>9</td><td>FG (Ground)</td><td>Metal</td></tr> <tr><td>B*</td><td>10</td><td></td><td></td></tr> <tr><td>Z</td><td>11</td><td></td><td></td></tr> <tr><td>Z*</td><td>12</td><td></td><td></td></tr> <tr><td></td><td>13</td><td></td><td></td></tr> <tr><td></td><td>14</td><td></td><td></td></tr> <tr><td></td><td>15</td><td></td><td></td></tr> <tr><td></td><td>16</td><td></td><td></td></tr> <tr><td></td><td>17</td><td></td><td></td></tr> <tr><td></td><td>18</td><td></td><td></td></tr> <tr><td></td><td>19</td><td></td><td></td></tr> <tr><td>FG (Ground)</td><td>20</td><td></td><td></td></tr> <tr><td>FG (Ground)</td><td>Metal</td><td></td><td></td></tr> </table>	P1 (Driver side) signal list		J1 (Encoder side) signal list		Name of signal chart	Pin No.	Name of signal chart	Pin No.	GND	2	A*	6	+5V	3	B	13	+5V	4	B*	5		5	Z	12		6	Z*	4	A	7	+5V	8	A*	8	GND	9	B	9	FG (Ground)	Metal	B*	10			Z	11			Z*	12				13				14				15				16				17				18				19			FG (Ground)	20			FG (Ground)	Metal			<p>NCR-XBDMA</p>				
	P1 (Driver side) signal list				J1 (Encoder side) signal list																																																																																												
	Name of signal chart	Pin No.			Name of signal chart	Pin No.																																																																																											
GND	2	A*	6																																																																																														
+5V	3	B	13																																																																																														
+5V	4	B*	5																																																																																														
	5	Z	12																																																																																														
	6	Z*	4																																																																																														
A	7	+5V	8																																																																																														
A*	8	GND	9																																																																																														
B	9	FG (Ground)	Metal																																																																																														
B*	10																																																																																																
Z	11																																																																																																
Z*	12																																																																																																
	13																																																																																																
	14																																																																																																
	15																																																																																																
	16																																																																																																
	17																																																																																																
	18																																																																																																
	19																																																																																																
FG (Ground)	20																																																																																																
FG (Ground)	Metal																																																																																																
E-E-2	NCR-XBCUA-200	20m																																																																																															
	-300	30m																																																																																															

● Motor cable without shield(PLN:For slow moving) chart

Dimension No./Model	Model	Length(L)	Dimensions	Connection table
M-A	NCR-XBBAA-030	3m		Signal name J1 Pin No. Cable color
	-050	5m		U 1 red
	-100	10m		V 2 white
	-150	15m		W 3 black
	-200	20m		E 4 green
	-300	30m		Connector kit for power cable CSZ-MOT
M-C-1	NCR-XBBDA-030	3m		Signal name J1 Pin No. Cable color
	-050	5m		U B1 red
	-100	10m		V B2 white
	-150	15m		W A1 black
	-200	20m		E A2 green
	-300	30m		Connector kit for power cable NCR-XBB4A
M-C-2	NCR-XBBGA-030	3m		Signal name J1 Pin No. Cable color
	-050	5m		U B1 red
	-100	10m		V B2 white
	-150	15m		W A1 black
	-200	20m		E A2 green
	-300	30m		Connector kit for power cable NCR-XBB4A
M-E	NCR-XBBJA-030	3m		Signal name J1 Pin No. Cable color
	-050	5m		U 1 red
	-100	10m		V 2 white
	-150	15m		W 3 black
	-200	20m		E 4 green
				Connector kit for power cable NCR-XBDDA
M-G-1	NCR-XBBMA-030	3m		Signal name J1 Pin No. Cable color
	-050	5m		U 1 red
	-100	10m		V 2 white
	-150	15m		W 3 black
	-200	20m		E 4 green
				Connector kit for power cable NCR-XBDDA
M-G-2	NCR-XBE7A-030	3m		Signal name J1 Pin No. Cable color
	-050	5m		U 1 red
	-100	10m		V 2 white
	-150	15m		W 3 black
	-200	20m		E 4 green
				Connector kit for power cable NCR-XBDDA
M-I	NCR-XBBPA-030	3m		Signal name J1 Pin No. Cable color
	-050	5m		U X red
	-100	10m		V Y white
	-150	15m		W Z black
	-200	20m		E G green
				Connector kit for power cable NCR-XBDEA
M-K-1	NCR-XBBSA-030	3m		Signal name J1 Pin No. Cable color
	-050	5m		U A red
	-100	10m		V B white
	-150	15m		W C black
	-200	20m		E D green
	-300	30m		Connector kit for power cable NCR-XBD9A
M-K-2	NCR-XBBTA-030	3m		Signal name J1 Pin No. Cable color
	-050	5m		U A red
	-100	10m		V B white
	-150	15m		W C black
	-200	20m		E D green
	-300	30m		Connector kit for power cable NCR-XBD9A
M-M-1	NCR-XBBWA-030	3m		Signal name J1 Pin No. Cable color
	-050	5m		U X red
	-100	10m		V Y white
	-150	15m		W Z black
	-200	20m		E G green
	-300	30m		Connector kit for power cable NCR-XBDHA
M-M-2	NCR-XBBYA-030	3m		Signal name J1 Pin No. Cable color
	-050	5m		U X red
	-100	10m		V Y white
	-150	15m		W Z black
	-200	20m		E G green
	-300	30m		Connector kit for power cable NCR-XBDHA

● Motor cable with shield type (PHS:For fast moving) reference chart

Dimension No./Model	Model	Length(L)	Dimensions	Connection table
M-B	NCR-XBBCA-030	3m		Signal name J1 Pin No. Cable color
	-050	5m		U 1 red
	-100	10m		V 2 white
	-150	15m		W 3 black
	-200	20m		E 4 green/yellow
	-300	30m		Connector kit for power cable CSZ-MOT
M-D-1	NCR-XBBFA-030	3m		Signal name J1 Pin No. Cable color
	-050	5m		U B1 red
	-100	10m		V B2 white
	-150	15m		W A1 black
	-200	20m		E A2 green/yellow
	-300	30m		Connector kit for power cable NCR-XBB4A
M-D-2	NCR-XBBIA-030	3m		Signal name J1 Pin No. Cable color
	-050	5m		U B1 red
	-100	10m		V B2 white
	-150	15m		W A1 black
	-200	20m		E A2 green/yellow
	-300	30m		Connector kit for power cable NCR-XBB4A
M-F	NCR-XBBLA-030	3m		Signal name J1 Pin No. Cable color
	-050	5m		U 1 red
	-100	10m		V 2 white
	-150	15m		W 3 black
	-200	20m		E 4 green/yellow
				Connector kit for power cable NCR-XBDDA
M-H-1	NCR-XBBOA-030	3m		Signal name J1 Pin No. Cable color
	-050	5m		U 1 red
	-100	10m		V 2 white
	-150	15m		W 3 black
	-200	20m		E 4 green/yellow
	-300	30m		Connector kit for power cable NCR-XBDDA
M-H-2	NCR-XBE9A-030	3m		Signal name J1 Pin No. Cable color
	-050	5m		U 1 red
	-100	10m		V 2 white
	-150	15m		W 3 black
	-200	20m		E 4 green/yellow
	-300	30m		Connector kit for power cable NCR-XBDDA
M-J	NCR-XBBRA-030	3m		Signal name J1 Pin No. Cable color
	-050	5m		U X red
	-100	10m		V Y white
	-150	15m		W Z black
	-200	20m		E G green/yellow
				Connector kit for power cable NCR-XBDEA
M-L-1	NCR-XBBUA-030	3m		Signal name J1 Pin No. Cable color
	-050	5m		U A red
	-100	10m		V B white
	-150	15m		W C black
	-200	20m		E D green/yellow
	-300	30m		Connector kit for power cable NCR-XBD9A
M-L-2	NCR-XBBVA-030	3m		Signal name J1 Pin No. Cable color
	-050	5m		U A red
	-100	10m		V B white
	-150	15m		W C black
	-200	20m		E D green/yellow
	-300	30m		Connector kit for power cable NCR-XBD9A
M-N-1	NCR-XBBXA-030	3m		Signal name J1 Pin No. Cable color
	-050	5m		U X red
	-100	10m		V Y white
	-150	15m		W Z black
	-200	20m		E G green/yellow
	-300	30m		Connector kit for power cable NCR-XBDHA
M-N-2	NCR-XBBZA-030	3m		Signal name J1 Pin No. Cable color
	-050	5m		U X red
	-100	10m		V Y white
	-150	15m		W Z black
	-200	20m		E G green/yellow
	-300	30m		Connector kit for power cable NCR-XBDHA

● Absolute position accuracy compensation

This option ensure the absolute position accuracy of τ DISC series.
There is three type of setting method of absolute position accuracy compensation data. Please refer to the charts in the below.

Encoder type : built-in interpolator unit type

Install the compensation data at factory		
Option model No.	NCR-XA□JD1	Effective absolute position accuracy compensation data function + install the compensation data
	NCR-XA□AD1	Measuring τ DISC absolute position accuracy compensation data (IPU)
Install the overcompensation data to servo driver by the customer		
Option model No.	NCR-XA□ID1	Effective absolute position accuracy compensation data function
	NCR-XA□BD1	Measuring τ DISC absolute position accuracy compensation data (IPU)

Encoder type : external interpolator unit type(When the servo driver connects to interpolator unit (IPU), the compensation data is set to servo driver automatically.)

Compensation data to be installed to the interpolator unit (IPU) the separate unit of encoder at the factory before shipment		
Option model No.	NCR-XA□ID1	Effective absolute position accuracy compensation data function
	NCR-XA□DD1	Measuring τ DISC absolute position accuracy compensation data (IPU)

※ In case VCI series is selected, □ in the model No. is "B", and VPS series selected, it will be "C".

● Overseas safety standard conformity

Some of τ DISC servomotor are compliant to overseas safety standard as listed in the below.

※ Please note that the model, specifications, and dimensions of conformed motors may be different from the standard models in the catalog.

[Conformed Safety standard]

①North America safety standard
UL1004-1, CSA22.2 NO.100(cUL)
UL file No. E254021

②European safety standard
EN60034-1, EN61800-3

Caution)By deciding the setting model (conditions) of the driver and motor.
The related standard to the EMC Directives will be achieved by that model.
Thus, it is necessary for the finally configured product to confirm and measure if the EMC compliance is applicable.

τ DISC servo motors with safety standard conformity

Conformed items of ① and ②	Conformed items of ②
D110-40F	ND180-55F
D170-100F	ND180-110L
D170-100L	ND250-55F(ABS)
D250-100F	ND250-110L(ABS)
D400-100L	ND400-55F(ABS)
D110-40L	ND400-110L(ABS)
D250-100L	ND250-55F(INC)
	ND250-110L(INC)
	ND400-55F(INC)
	ND400-110L(INC)

※ For the other model not listed, please contact to our sales department.

● RoHS command corresponding

τ DISC series correspond to RoHS command.

● Special specifications

Besides standard lineup of τ DISC series, we deal with following requirement as special model.

- Built-in motor
(Built-in air bearing, coater and stator of ball bearing spindle or rotor and stator is supplied)
- Change material and surface treatment
- Improve torque and revolution
- Exchange to specified connector and shield cable
- Expand hollow size and change hollow shape
- Outer circumference encoder specification
- Forced air or water cooling
- Improve rotational accuracy (Bearing change). To improved flatness or parallelism
- Dustproof system

※ Please consult with our sales dept, if you have other requirement.

AC Servo driver / controller

VCI Series



50W~20kW

◎VCI-D type

It is the high performance servo driver to optimize the motor potential for the needs of "High response" to "Ultra slow".
Pulse train, Speed control, and Torque control mode can be selected.

◎VCI-C1 type

In addition to the high performance servo driver VCI-D, multiple functions are set up to VCI-C1 servo controller.
It has the program operation functions such as Stand-alone positioning and Speed/ Torque/ Spinner control.

◎VCI-C6 type

In addition to the high performance servo driver VCI-D, Free-curve control functions are set up for VCI-C6 servo controller.
It works as the slave axis following the master axis movement like electric cam.

- RoHS command corresponding
- CE marking corresponded (All type), UL/cUL corresponded (800W or less)



- Corresponding to network
 - Field network--[CC-Link/DeviceNet]
 - Motion network--[SSCNETIII]
[MECHATROLINK-III]

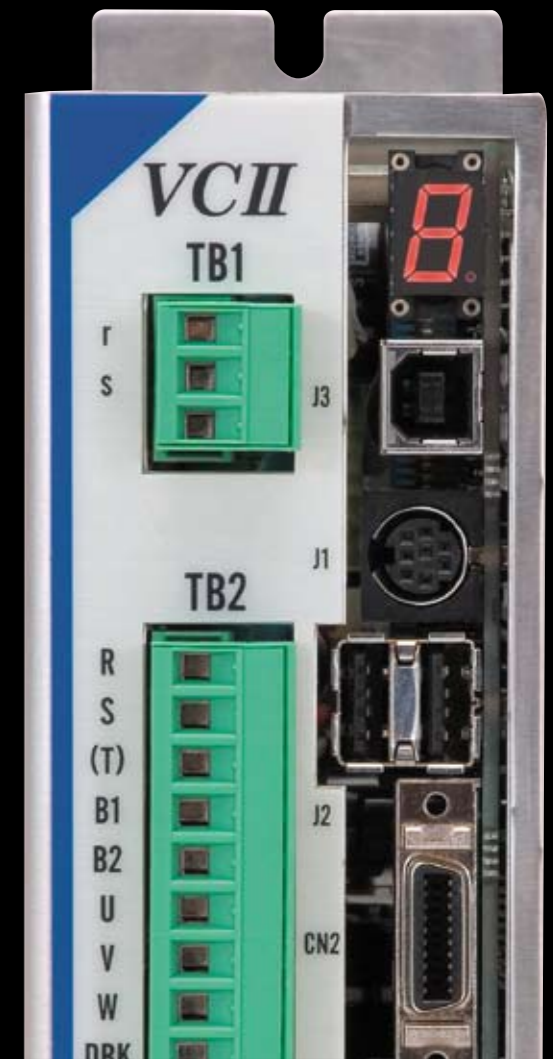

AC Servo driver

VPS Series



50W~1.6kW

◎I/O type / CC-Link type

servo driver easy to use and high cost performance model.
Pulse train/Mode selection of Speed control.
7 points positioning and Zero return function are equipped as standard function.
For the other standard functions; Feed-forward control torque control, resonance control filter function, 4ch real time oscilloscope function.

- CE marking, UL/cUL conformity



- RoHS command corresponding

AC Servo driver / controller

VCII Series

D type / C1 type / C6 type



High performance servo driver VC II series

High performance and versatility control function

High performance type motor for utilizing its optimal performance from high response to ultra slow motion

Useful filter function to control the vibration at the distal end of machine.

Auto notch filter function to increase efficiency of resonance control operation.

4 kinds of Gain selection function (GSEL) to enable to select suitable gain according to the condition of load.

Effective feed forward function to shorten the settlement time.

Selectable network

Motion network.....SSCNETIII/MECHATROLINK-III

Field network.....CC-Link/DeviceNet

Model

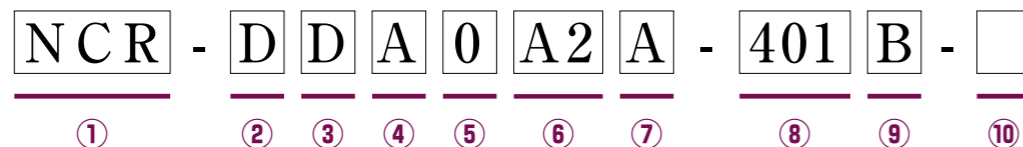

①	NCR...Nikki AC servo controller series	⑥	Input power source specifications A1...AC100V A2...AC200V
②	Classification of Product D...Driver C...Controller	⑦	Design order A→B→C...Starting from A
③	Series R...Regenerative driver S...Regenerative controller	⑧	Output capacity Ex.)401...4 0 1 =40×10 ¹ =400W Exponent of accumulation of 10 Effective digit
④	Machine model type D...VCII series	⑨	Motor combination NON...Synchronous/Induction AC servomotor B...τDISC D/ND series / τlinear NLA-MA-NA type C...τlinear NLA-S type D...τDISC HD-ND-c series / τlinear NVA-NLD series
⑤	Function type A...τDISC motor / τlinear B...Synchronous motor C...Induction motor O...Drive 1...Positioning control controller 6...Free-curve control controller	⑩	Encoder combination Special specifications NON...Standard type T**...Special specifications

VCII Index

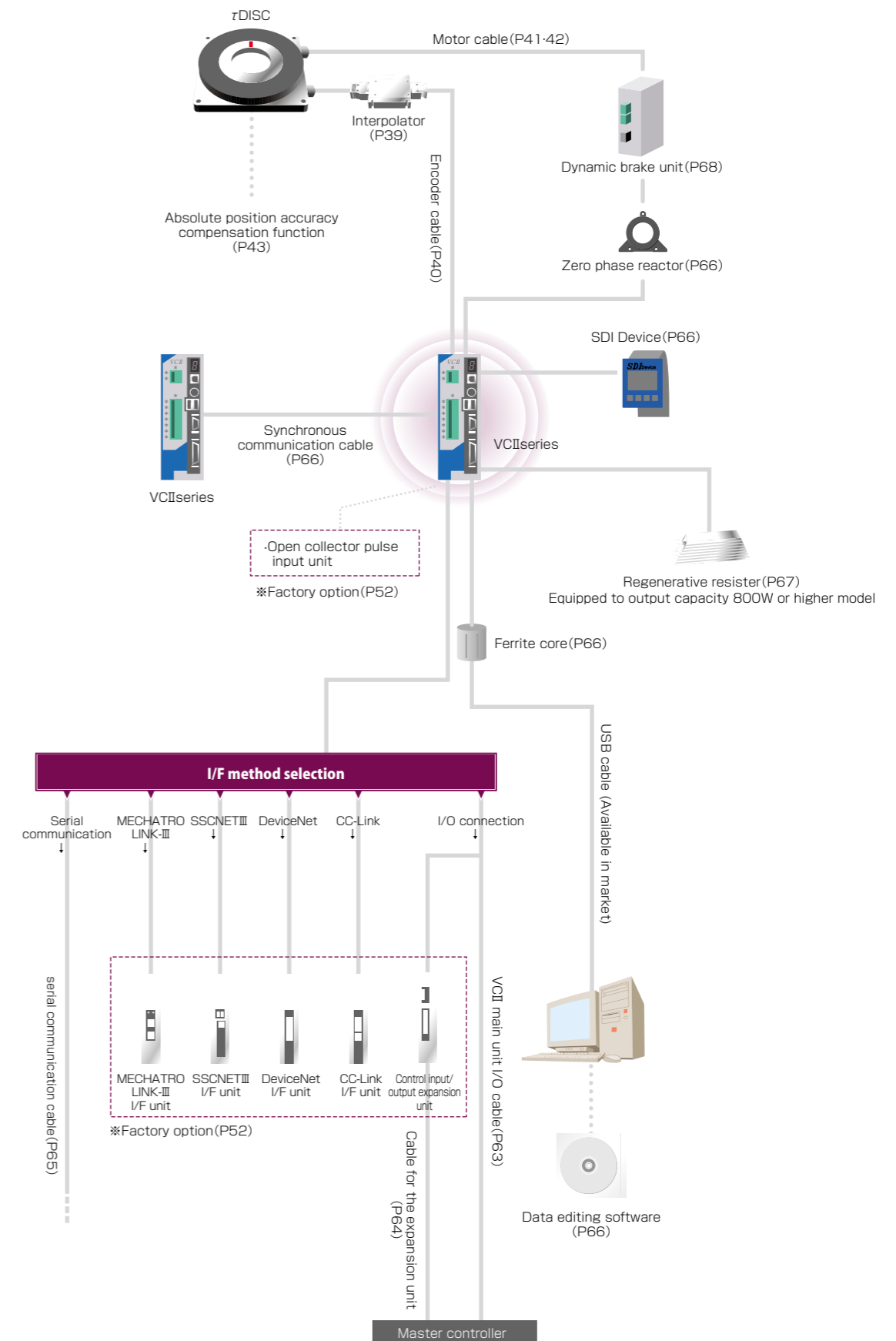

※Option in [] will be installed to VCII unit at our factory before the shipment.

VCII series

VCII series

VCIIseries Common specifications

Item	Specification
Ambient Condition	Temperature Operating temperature 0~55°C 0~50°C(When UL standard is applied) Storage temperature -20~60°C ※
	Humidity 85% or lower, No condensation ※
	Installation location No harmful substance such as corrosive gas, grinding fluid, metal powder, and oil are not allowed in the installation location.
	Altitude 1000m or lower
Cooling method	Capacity 800W or less : Natural air cooling, Capacity 1.2kw or more : Forced air cooling
Installation method	Panel installation type
Resistance to vibration	0.5G(10~50Hz)
Shock resistant	5G
Noise resistance	FT / B ±2000V(Frequency 5 / 100kHz, Synchronous 300ms), 1 minute
	Radiation noise ±1000V(50ns, 10cm), 1 minute
	Electro-static noise ±10kVA(between earth and case)

※Please avoid using at high temperature and high humidity conditions since the Life is heavily depended on the temperature and moisture.

VCIIseries Special specifications

Item	Specification
Model	NCR-□DA□A 1A-101□ 1A-201□ 2A-201□ 2A-401□ 2A-801□ 2A-152□
Output capacity	W 100 200 200 400 800 1.5k
Input power supply	Voltage specifications AC100~115V, 50 / 60Hz single phase AC200~230V, 50 / 60Hz 3-phase
	Allowable voltage change AC90~121V, 50 / 60Hz AC180~242V, 50 / 60Hz
Drive method	3-phase sin wave PWM
Power capacity (at rated output)	kVA 0.3 0.6 0.6 1.1 1.8 3.0
Continuous output current	Arms 2.0 3.4 2.0 3.4 5 (6.8) ※4 10.0
Instant output current	Arms 6.0 9.9 6.0 9.9 17.0 30.0
Control method	Semi closed loop with encoder (linear sensor) feedback
Brake method	Regenerative brake : regenerative resistor external installation
Carrier frequency	kHz 25 16
Speed control range ※1	1:5000
Max speed frequency	Mpps 20
No fuse breaker (Rated current) ※2	A 5 10 5 5 10 10
Mass ※3	kg 1.0 1.4 1.0 1.4 2.4 4.0
Option	Regenerative resistor (Refer to P67)

Item	Specification
Model	NCR-□DA□A 2A-222□ 2A-402□ 2A-752□ 2A-113□ 2A-153□ 2A-203□
Output capacity	W 2.2k 4.0k 7.5k 11.0k 15.0k 20.0k
Input power supply	Voltage specifications AC200~230V, 50 / 60Hz 3-phase
	Allowable voltage change AC180~242V, 50 / 60Hz
Drive method	3-phase sin wave PWM
Power capacity (at rated output)	kVA 4.7 7.8 15 ※5 20 ※5 25 ※5 30 ※5
Control power capacity	W - - 36 36 36 56
Continuous output current	Arms 16.0 27.0 41.8 47.7 62.6 87.3
Instant output current	Arms 48.0 78.0 83.6 95.4 125.2 174.6
Control method	Semi closed loop with encoder (linear sensor) feedback
Brake method	Regenerative brake : regenerative resistor external installation
Carrier frequency	kHz 16 10
Speed control range ※1	1:5000
Max speed frequency	Mpps 20
No fuse breaker (Rated current) ※2	A 15 30 60 75 100 125
Mass ※3	kg 4.0 6.0 7.4 7.7 10.0 18.5
Option	Regenerative resistor (Refer to P67)

※1 When the load is 100%, the motor will be not stopped within the speed control range.

※2 Select a molded case circuit breaker which has appropriate interruption capacity for the power capacity to achieve protective coordination.

※3 Weight without options.

※4 When UL standard is not applied, the rated current is 6.8A.

※5 Power supply capacity.

VCIIseries Function specifications

Item	Specification		
	VCII-D (NCR-DDAO)	VCII-C1 (NCR-CDA1)	VCII-C6 (NCR-CDA6)
Number of control axis	1 axis		
Encoder feedback	25Mpps		20Mpps
Input frequency	(However, frequency of encoder pulse 4-multiplication)		(However, frequency of encoder pulse 4-multiplication)
Operation mode	Speed control·Torque control	Automatic·Manual	Automatic·Manual
	Pulse train command·Simple positioning	Zero point return·Pulse train	Zero point return·Servo lock
Command input style	VCII-D/CI type Pulse train command	①90-degree phase difference pulse ②Directional pulse ③Directional signal + sending pulse «Line driver or open collector output (option) compatible. However, line drive method is recommendable, due to noise resistance»	
	VCII-C6 type Master axis positioning command	«Maximum input frequency : 6.25Mpps» «Maximum input frequency : 5Mpps» «GND is common for line receiver input; thus, pay attention to noise»	
	Analog command	Speed control run·Torque control run DC -10V~ +10V, Input resolution 14bit	④Servo control communication
	Internal command	Simple positioning/Zero point return/Manual run, by internal pulse train command	Program run by internal stored data 280 points (Address 0~255 set by control signal)
Major function	Common type	Zero point return run, Manual (jog) run, Serial communication run, Self-diagnosis, Torque limit, Electronic thermal	
	Each type	Pulse train run Simple positioning Pulse train command correction	Pulse train run, Program run (Positioning, Simple continuous positioning, External trigger positioning, 4 rules of arithmetic/Logic computing, Timer, No-conditional/conditional jump, Sub-routine spinner control), Electric gear ratio set, Backlash compensation Program run (Continuous control) Program run (Free curving control)
Acceleration deceleration pattern	Linear accel-decel-S-letter accel-decel		
Auto-tuning function	Parameter setting can cope with cases even in relatively big inertia ratio		
Gain select function	①With combination of GSEL signal, 4-type gain select is enabled ②Position loop gain also corresponds to gain select		
Control input signal (External input signal Basic 8 points) ※	Drive (DR) Speed/Torque select (SS1, SS2) Simple positioning start (PST) Address set (PS1~PS3) Zero point return (ORG) Command direction select (SSD)	Auto start (PST) · Address set (PS1~8) · Hold (HLD) External trigger (TRG) · M complete (MFIN) · Program cancel (PCAN) Block stop (BSTP) · External auto start inhibit (EPIH) · Jog speed change (JOSP)	Backlash alignment progress (D11) · Backlash delay (D12) · Electronic clutch (D14) · Master axis selection (D18) · Cycle end (D21) · Pattern selection (D22/D24/D28) · Internal master axis speed selection (MSSP)
		Command direction select (SSD)	
Output signal (Basic 4 points) ※2	Servo ready (RDY) · Alarm (ALM*) · Warning (WNG*) · Position complete (PN) · In torque limit (LIM) Speed zero (SZ) · Brake release (BRK) · Soft limit switch (SLSA, SLSB) · Encoder maker (OCM)		
	In speed run mode (SMOD) In torque run mode (TMOD) In simple positioning run mode (NMOD) In pulse train run mode (PMOD)	Rough matching (PRF) · Program end (PEND) · Auto run ready (PRDY) · In manual run (MMOD) · In auto run (AMOD) · In zero point return run (HM0D) · M strobe (MSTB) · General output (OUT1~8) · M output (MO1~80)	Electronic clutch stopping (FCRP) In free curving motion (FC) Master axis speed zero (MSZ) Mode in servo lock (PMOD)
Encoder pulse output	90° phase difference pulse train output (Division output possible: maximum output frequency of A/B-phase 2-signal is 20Mpps with 4-multiplication)		
Operation/display function	Device front LCD module or optional SDI device can display input of each data and various statuses		
Filter function	Notch filter, Torque command filter, Disturbance correction filter, Active vibration control filter		
Monitor function	①Control signal status is displayed on device front LCD module or on signal display block of optional SDI device ②Each type operation conditions, setting status (data), error detection content history record is displayed on device front LCD module or on data display block of optional SDI device ③Analog monitor: 2 items (It can monitor 2 items that are selected with parameter in various operation status) ④Various monitoring is enable with USB compatible exclusive editing software (Option)		
Data sustain function	Below data is sustained in nonvolatile memory (Up to 10,000 times of rewriting is possible to nonvolatile memory) : Parameter, alarm history record (History record up to last five occasions is sustained. However, event that is identical to the latest alarm is not registered)		
Protective function	IPM error, Excessive voltage, Low voltage, Excessive speed, Overload (electronic thermal), Regenerative resistor overload, Deviation over flow, Communication error, Data error, CPU error, Encoder error, automatic magnetic pole detection error, Absolute encoder error, etc.		
Communication function	Serial communication (RS-422A) enable various data transceiving		
	By USB (1.1/2.0 standard compliance), it can communicate with data editing software		

※ Refer to P51-52 "external connection diagram" for initial value of external input/output 8/4 point signal.

The value except initial value is used in remote control or allocated according to input/output signal allocation.

* of signal sign is non logic. (*) sign is the signal which can change logic by parameter.

TDISC⇄VCII series matching chart

■D series⇄VCII series matching chart

rDISC servo motor (D series)				When combined		Input Voltage (ACV)		VCII series			Dynamic brake unit
Type	Model (Flange type)	Model (Flange-less)	Rated torque	Peak torque (N.m)	VCII-D			VCII-C1		VCII-C6	
								Model			
D110	40	NMR-FADBA2C-061A		2	6	Single phase 100 3 phase 200	NCR-DDA0A1A-101B	NCR-CDA1A1A-101B	NCR-CDA6A1A-101B	NCR-XABCA2B-801-UL	
	60	NMR-FAEBA2C-121A		4	12		NCR-DDA0A2A-201B	NCR-CDA1A2A-201B	NCR-CDA6A2A-201B		
D170	40	NMR-FDDBA2D-201A		7.5	22.5	Single phase 100 3 phase 200	NCR-DDA0A1A-201B	NCR-CDA1A1A-201B	NCR-CDA6A1A-201B		
	100	NMR-FDFBA2C-701A		22.5	67		NCR-DDA0A2A-401B	NCR-CDA1A2A-401B	NCR-CDA6A2A-401B		
D250	40	NMR-FEDBA2C-401A		20.7	60	Single phase 100 3 phase 200	NCR-DDA0A1A-201B	NCR-CDA1A1A-201B	NCR-CDA6A1A-201B		
	100	NMR-FEFBA2C-122A		62	186		NCR-DDA0A2A-152B	NCR-CDA1A2A-152B	NCR-CDA6A2A-152B		
D400	40	NMR-FFDBA2C-801A		67	134	3 phase 200	NCR-DDA0A2A-801B	NCR-CDA1A2A-801B	NCR-CDA6A2A-801B		NCR-XABCA2B-801-UL
	100	NMR-FFFBA2C-252A		200	400		NCR-DDA0A2A-222B	NCR-CDA1A2A-222B	NCR-CDA6A2A-222B		NCR-XABCA2B-222-UL
	175	NMR-FUJBA2D-212AZ		500	1000		NCR-DDA0A2A-402B	NCR-CDA1A2A-402B	NCR-CDA6A2A-402B		NCR-XABCA2B-402-UL
	275 (High rigidity)	NMR-FUJBA2D-472AZ		700	1800		NCR-DDA0A2A-752B	NCR-CDA1A2A-752B	NCR-CDA6A2A-752B		NCR-XABCA2B-113-UL
D630	125	NMR-FUVHA2A-662A		500	1000	3 phase 200	NCR-DDA0A2A-153B	NCR-CDA1A2A-153B	NCR-CDA6A2A-153B	-	
	175	NMR-FUVVA2A-662A		500	1000		NCR-DDA0A2A-402B	NCR-CDA1A2A-402B	NCR-CDA6A2A-402B	NCR-XABCA2B-402-UL	
	225	NMR-FVGA2C-322A		1000	2000		NCR-DDA0A2A-113B	NCR-CDA1A2A-113B	NCR-CDA6A2A-113B	NCR-XABCA2B-113-UL	
	225	NMR-FVBA2C-672A		1500	3000		NCR-DDA0A2A-203B	NCR-CDA1A2A-203B	NCR-CDA6A2A-203B	-	
	470	NMR-FGPHA2A-133AGZ		3000	5800						

■HD series⇄VCII series matching chart

rDISC servo motor (HD series)				When combined		Input Voltage (ACV)		VCII series			Dynamic brake unit
Type	Model (Flange type)	Model (Flange-less)	Rated torque	Peak torque (N.m)	VCII-D			VCII-C1		VCII-C6	
								Model			
D140	160	NMR-FCHBA2D-661A		21	58.8	3 phase 200	NCR-DDA0A2A-801D	NCR-CDA1A2A-801D	NCR-CDA6A2A-801D	NCR-XABCA2B-801-UL	
	180G (Forced air cooling)	-		27.5	63		NCR-DDA0A2A-152D	NCR-CDA1A2A-152D	NCR-CDA6A2A-152D	NCR-XABCA2B-222-UL	
D170	185	NMR-FCIBA2D-751A		24	67.2	3 phase 200	NCR-DDA0A2A-152D	NCR-CDA1A2A-152D	NCR-CDA6A2A-152D	NCR-XABCA2B-222-UL	
D250	225	-		53	154		NCR-DDA0A2A-222D	NCR-CDA1A2A-222D	NCR-CDA6A2A-222D	NCR-XABCA2B-222-UL	
D250	200	-		115	345	3 phase 200	NCR-DDA0A2A-402D	NCR-CDA1A2A-402D	NCR-CDA6A2A-402D	NCR-XABCA2B-402-UL	

■ND-c series⇄VCII series with built-in Interpolator unit encoder matching chart

rDISC servo motor (ND-c series)				When combined		Input Voltage (ACV)		VCII series			Dynamic brake unit
Type	Model (Incremental)	Model (Absolute)	Rated torque	Peak torque (N.m)	VCII-D			VCII-C1		VCII-C6	
								Model			
ND110	65-C	NMR-CAEIA2A-071A		2.4	7.2	Single phase 100 3 phase 200	NCR-DDA0A1A-101D	NCR-CDA1A1A-101D	NCR-CDA6A1A-101D	NCR-XABCA2B-801-UL	
	85-C	NMR-CAUIA2A-151A		4.8	14.4		NCR-DDA0A2A-201D	NCR-CDA1A2A-201D	NCR-CDA6A2A-201D		
ND140	70-C	NMR-CREIA2A-151A		4.8	14.4	Single phase 100 3 phase 200	NCR-DDA0A1A-201D	NCR-CDA1A1A-201D	NCR-CDA6A1A-201D		
	95-C	NMR-CRFA2A-311A		9.6	28.8		NCR-DDA0A2A-401D	NCR-CDA1A2A-401D	NCR-CDA6A2A-401D		
ND180	70-C	NMR-CSMIA2A-281A		9	27	3 phase 200	NCR-DDA0A1A-201D	NCR-CDA1A1A-201D	NCR-CDA6A1A-201D		
	95-C	NMR-CSEIA2A-561A		18	54		NCR-DDA0A2A-401D	NCR-CDA1A2A-401D	NCR-CDA6A2A-401D		
ND250	70-C	NMR-CTEIA2A-501A		27	81	3 phase 200	NCR-DDA0A2A-801D	NCR-CDA1A2A-801D	NCR-CDA6A2A-801D		
	95-C	NMR-CTFA2A-841A		45	112.5		NCR-DDA0A2A-401D	NCR-CDA1A2A-401D	NCR-CDA6A2A-401D		
ND400	70-C	NMR-CUEIA2A-951A		76	190	3 phase 200	NCR-DDA0A2A-801D	NCR-CDA1A2A-801D	NCR-CDA6A2A-801D		
	95-C	NMR-CUIA2A-192A		152	380		NCR-DDA0A2A-222D	NCR-CDA1A2A-222D	NCR-CDA6A2A-222D		NCR-XABCA2B-222-UL

■ND-c series⇄VCII series with external Interpolator unit (IPU) encoder matching chart

rDISC servo motor (ND-c series)				When combined		Input Voltage (ACV)		VCII series			Dynamic brake unit
Type	Model (Incremental)	Model (Absolute)	Rated torque	Peak torque (N.m)	VCII-D			VCII-C1		VCII-C6	
								Model			
ND110	65-C	NMR-CAEGA2A-071A		2.4	7.2	Single phase 100 3 phase 200	NCR-DDA0A1A-101D	NCR-CDA1A1A-101D	NCR-CDA6A1A-101D	NCR-XABCA2B-801-UL	
	85-C	NMR-CAUGA2A-151A		4.8	14.4		NCR-DDA0A2A-201D	NCR-CDA1A2A-201D	NCR-CDA6A2A-201D		
ND140	70-C	NMR-CREGA2A-151A		4.8	14.4	Single phase 100 3 phase 200	NCR-DDA0A1A-201D	NCR-CDA1A1A-201D	NCR-CDA6A1A-201D		
	95-C	NMR-CRFGA2A-311A		9.6	28.8		NCR-DDA0A2A-401D	NCR-CDA1A2A-401D	NCR-CDA6A2A-401D		
ND180	70-C	NMR-CSMGA2A-281A		9	27	3 phase 200	NCR-DDA0A1A-201D	NCR-CDA1A1A-201D	NCR-CDA6A1A-201D		
	95-C	NMR-CSEGA2A-561A		18	54		NCR-DDA0A2A-401D	NCR-CDA1A2A-401D	NCR-CDA6A2A-401D		
ND250	70-C	NMR-CTEGA2A-501A		27	81	3 phase 200	NCR-DDA0A2A-801D	NCR-CDA1A2A-801D	NCR-CDA6A2A-801D		
	95-C	NMR-CTFGA2A-841A		43	108		NCR-DDA0A2A-401D	NCR-CDA1A2A-401D	NCR-CDA6A2A-401D		
ND400	70-C	NMR-CUEGA2A-951A		76	190	3 phase 200	NCR-DDA0A2A-801D	NCR-CDA1A2A-801D	NCR-CDA6A2A-801D		
	95-C	NMR-CUFGA2A-192A		152	380		NCR-DDA0A2A-222D	NCR-CDA1A2A-222D	NCR-CDA6A2A-222D		NCR-XABCA2B-222-UL
ND400	120-C	-		250	600	3 phase 200	NCR-DDA0A2A-113D	NCR-CDA1A2A-113D	NCR-CDA6A2A-113D	NCR-XABCA2B-113-UL	

■ND series⇄VCII series matching chart

rDISC servo motor (ND series)				When combined		Input Voltage (ACV)		VCII series			Dynamic brake unit
Type	Model (Incremental)	Model (Absolute)	Rated torque	Peak torque (N.m)	VCII-D			VCII-C1		VCII-C6	
								Model			
ND110	50	NMR-NAMBA2A-071A		2.4	7.2	Single phase 100 3 phase 200	NCR-DDA0A1A-101B	NCR-CDA1A1A-101B	NCR-CDA6A1A-101B	NCR-XABCA2B-801-UL	
	100	NMR-NPEBA2A-201A		7	20.3		NCR-DDA0A2A-201B	NCR-CDA1A2A-201B	NCR-CDA6A2A-201B		
ND180	55	NMR-NDMGA2A-201A		9	27	Single phase 100 3 phase 200	NCR-DDA0A1A-201B	NCR-CDA1A1A-201B	NCR-CDA6A1A-201B		
	110	NMR-NSFGA2B-701A		27	81		NCR-DDA0A2A-401B	NCR-CDA1A2A-401B	NCR-CDA6A2A-401B		
ND250	55	NMR-NEMGA2B-401A		21.5	65	3 phase 200	NCR-DDA0A2A-152B	NCR-CDA1A2A-152B	NCR-CDA6A2A-152B		NCR-XABCA2B-222-UL
	110	NMR-NTFGA2B-122A		27	81		NCR-DDA0A2A-401B	NCR-CDA1A2A-401B	NCR-CDA6A2A-401B		NCR-XABCA2B-801-UL
ND400	55	NMR-NFMGA2B-801A		67	201	3 phase 200	NCR-DDA0A2A-801B	NCR-CDA1A2A-801B	NCR-CDA6A2A-801B		NCR-XABCA2B-222-UL
	110	NMR-NUFHA2B-252A		82	246		NCR-DDA0A2A-152B	NCR-CDA1A2A-152B	NCR-CDA6A2A-152B		NCR-XABCA2B-222-UL
	175	NMR-NUIGA2A-472AZ		76	190		NCR-DDA0A2A-222B	NCR-CDA1A2A-222B	NCR-CDA6A2A-222B		NCR-XABCA2B-222-UL
	175	NMR-NUIHA2A-472AZ		215	603		NCR-DDA0A2A-801B	NCR-CDA1A2A-801B	NCR-CDA6A2A-801B		NCR-XABCA2B-801-UL
	175	NMR-NUIGA2A-862AZ		450	900		NCR-DDA0A2A-222B	NCR-CDA1A2A-222B	NCR-CDA6A2A-222B	NCR-XABCA2B-222-UL	

*Refer to P68 for dimension of dynamic brake unit.

VCII series

VCII series

VCII series dimensions

AC100V

NCR-□DA□A1A-101□

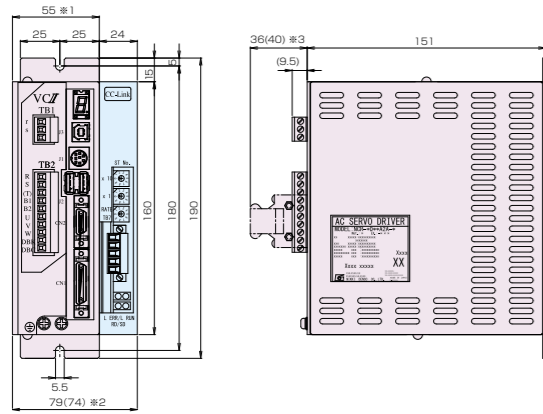

NCR-□DA□A1A-201□

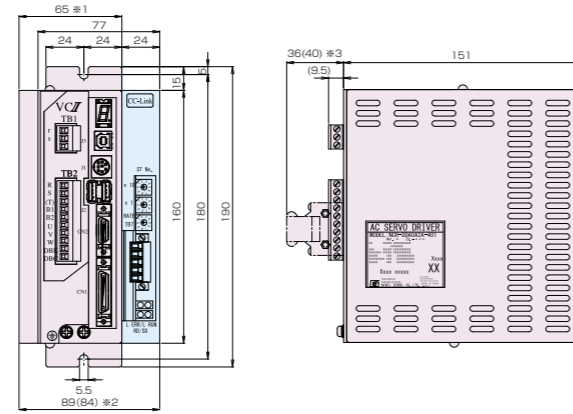

AC200V

NCR-□DA□A2A-201□

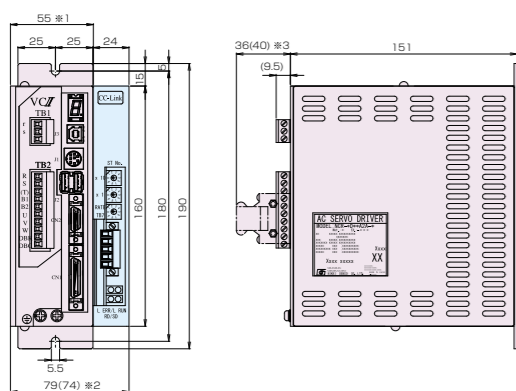

NCR-□DA□A2A-401□

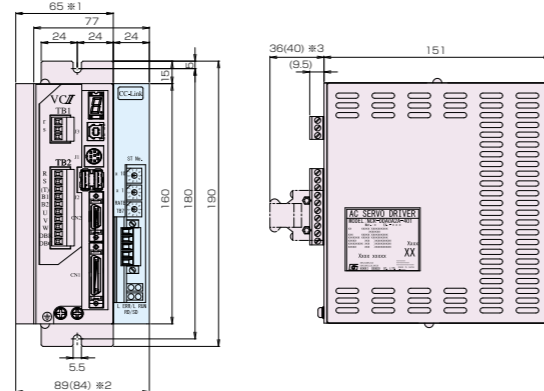

NCR-□DA□A2A-801□

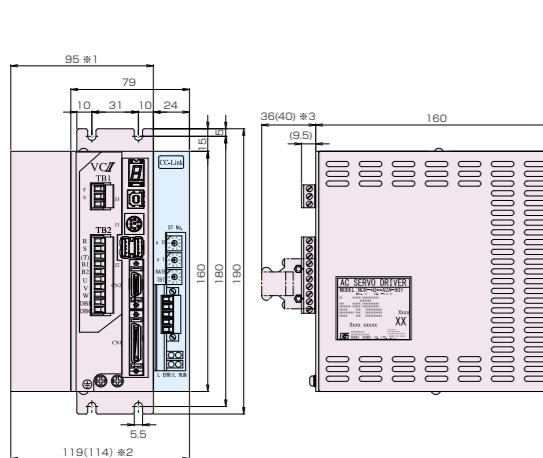

NCR-□DA□A2A-152□/222□

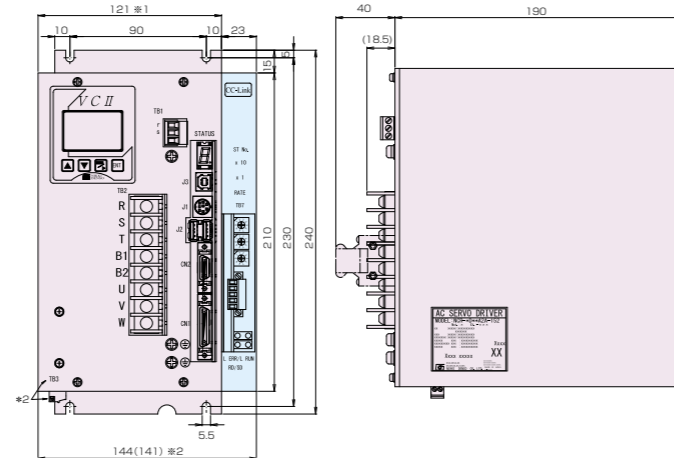

*1...The unit size of VCII series.

*2...The size of VCII series with options of CC-Link, DeviceNet, MECHATROLINK-III and SSCNETIII interface unit.
The size of VCII series with the input/output expansion unit is indicated in ().
For model name of each option, refer to P52 [VCII series factory option].

*3...The size of connector height of the input/output expansion unit indicated in ().

VCII series dimensions

AC200V

NCR-□DA□A2A-402□

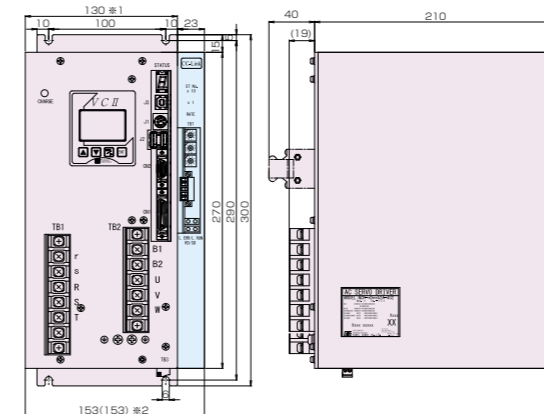

NCR-□DA□A2A-752□/113□

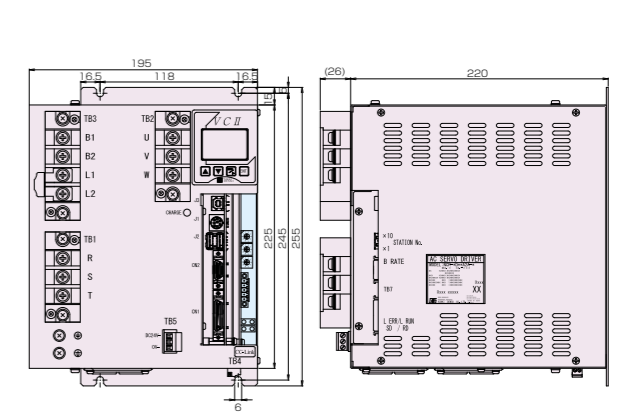

*The size is the same when the interface unit option is installed.

NCR-□DA□A2A-153□

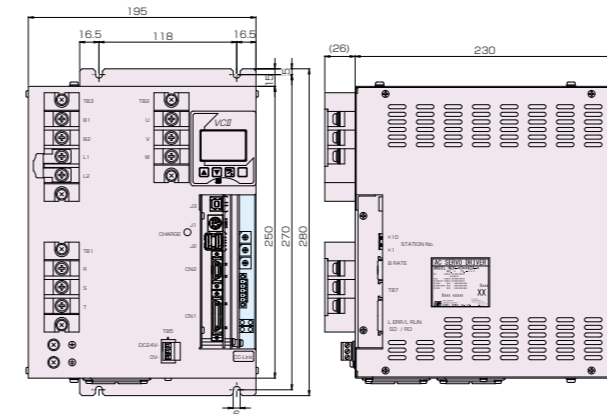

*The size is the same when the interface unit option is installed.

NCR-□DA□A2A-203□

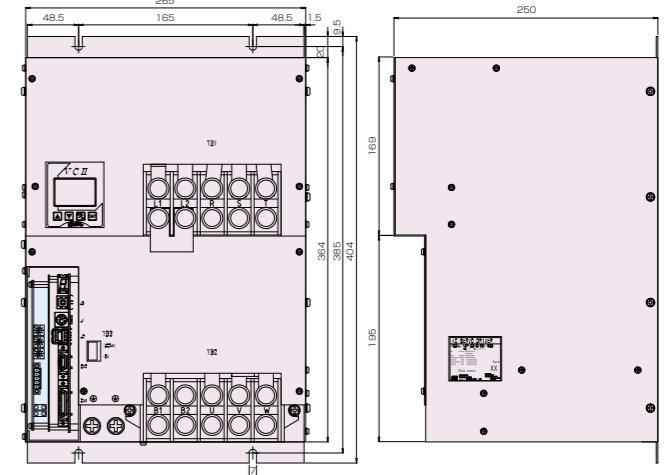

*The size is the same when the interface unit option is installed.

VCII series factory option

Factory option will be installed at our factory before the shipment. Please specify when you order.
Please note that it is unable to add factory option to VCII by yourself.

I/F unit option

When setting up VCII, it is possible to set up following network I/F unit or control input/output extension unit (unable to set up multi-units)
Network I/F unit enables network connection to other maker's product which corresponded with each network.
Control input/output extension unit is the unit which adds input/output signal to connect to I/O. (For standard input 8 points, output 4 points)

■The list of I/F unit option

VCII model	I/F unit	Network I/F unit			Control input/output extension unit
		MECHATROLINK-III I/F unit	SSCNETIII I/F unit	CC-Link I/F unit	
NCR-□DA□A□A-101□					
NCR-□DA□A□A-201□		NCR-XABPD1A-201/401	NCR-XABLD1A-201/401	NCR-XAB7D1A-201/401	NCR-XAB6D1A-201/401
NCR-□DA□A2A-401□					
NCR-□DA□A2A-801□		NCR-XABPD1A-801	NCR-XABLD1A-801	NCR-XAB7D1A-801	NCR-XAB6D1A-801
NCR-□DA□A2A-152□					
NCR-□DA□A2A-222□		NCR-XABPD1A-152/222	NCR-XABLD1A-152/222	NCR-XAB7D1B-152/222	NCR-XAB6D1B-152/222
NCR-□DA□A2A-402□		NCR-XABPD1A-402	NCR-XABLD1A-402	NCR-XAB7D1A-402	NCR-XAB6D1A-302/402
NCR-□DA□A2A-752□					
NCR-□DA□A2A-113□		NCR-XABPD1A-153	NCR-XABLD1A-153	NCR-XAB7D1A-153	NCR-XAB6D1A-153
NCR-□DA□A2A-153□					
NCR-□DA□A2A-203□		NCR-XABPD1A-203	NCR-XABLD1A-203	NCR-XAB7D1A-203	NCR-XAB6D1A-203

Pulse train command open collector receiving unit

For pulse train command to VCII, the unit enables open collector method of photo coupler.

Model
NCR-XAD2DOA

Specifications and the external connection diagram for VCI series with the built-in type interpolator unit encoder.

①-1

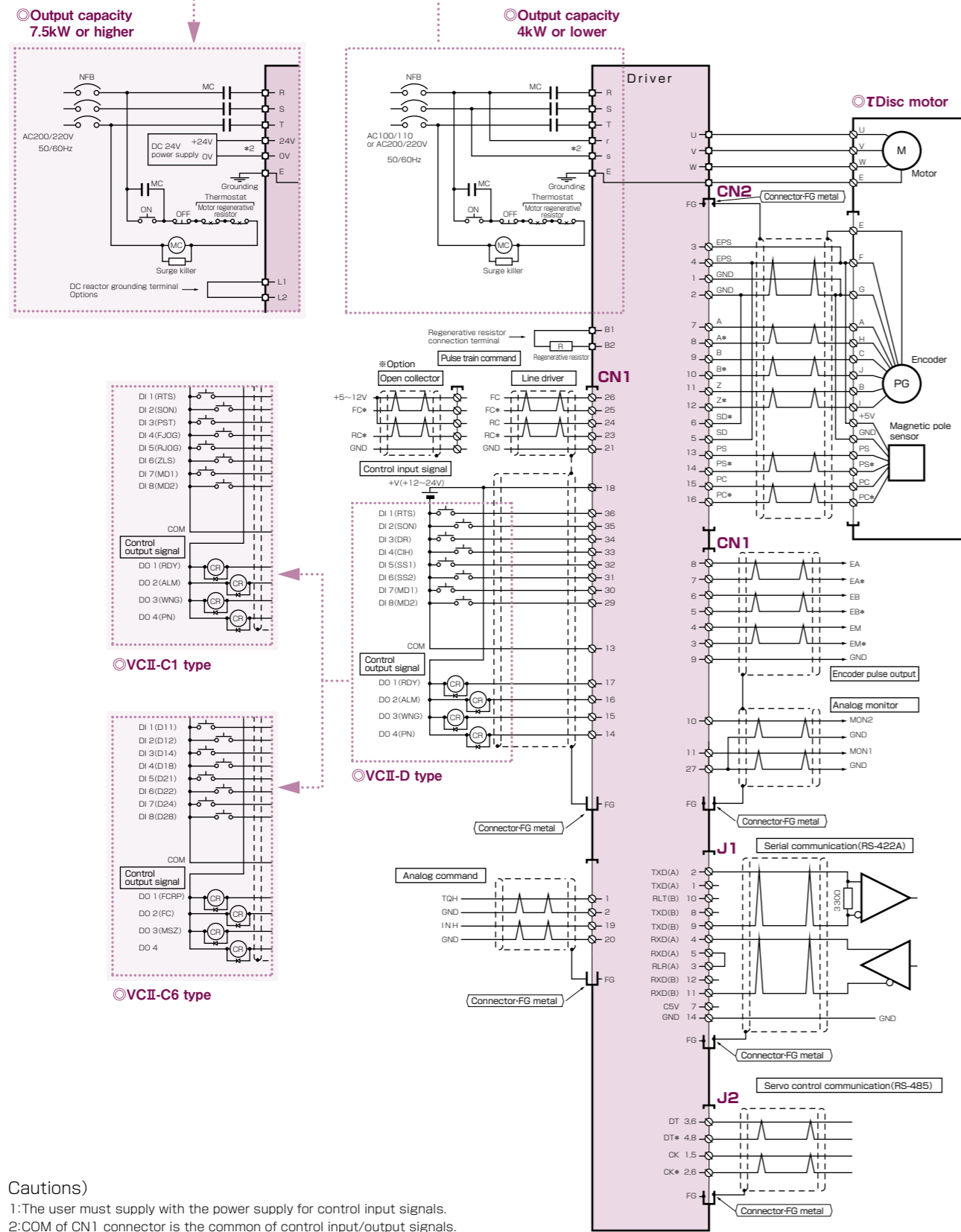

- Cautions)
- 1:The user must supply with the power supply for control input signals.
 - 2:COM of CN1 connector is the common of control input/output signals.
GND is the common of inner control power source (5V) in the device.
 - 3:Common wiring should not be done because COM of CN1 and GND are isolated.
 - 4:The status of switch connected to the control input signals indicates the state of OFF of each input signals
 - 5:The pin not mentioned in this diagram is NC
 - 6:Please refer to the instruction manual of "VCI series options" if the user is using the control input/output expansion unit.
 - 7:GND of pulse train command should be connected in case of using the line receiver option.
 - 8:The initial value of is indicated in () of control input/output signals

Specifications and the external connection diagram for VCI series with the separate type interpolator unit (IPU) encoder.

①-2

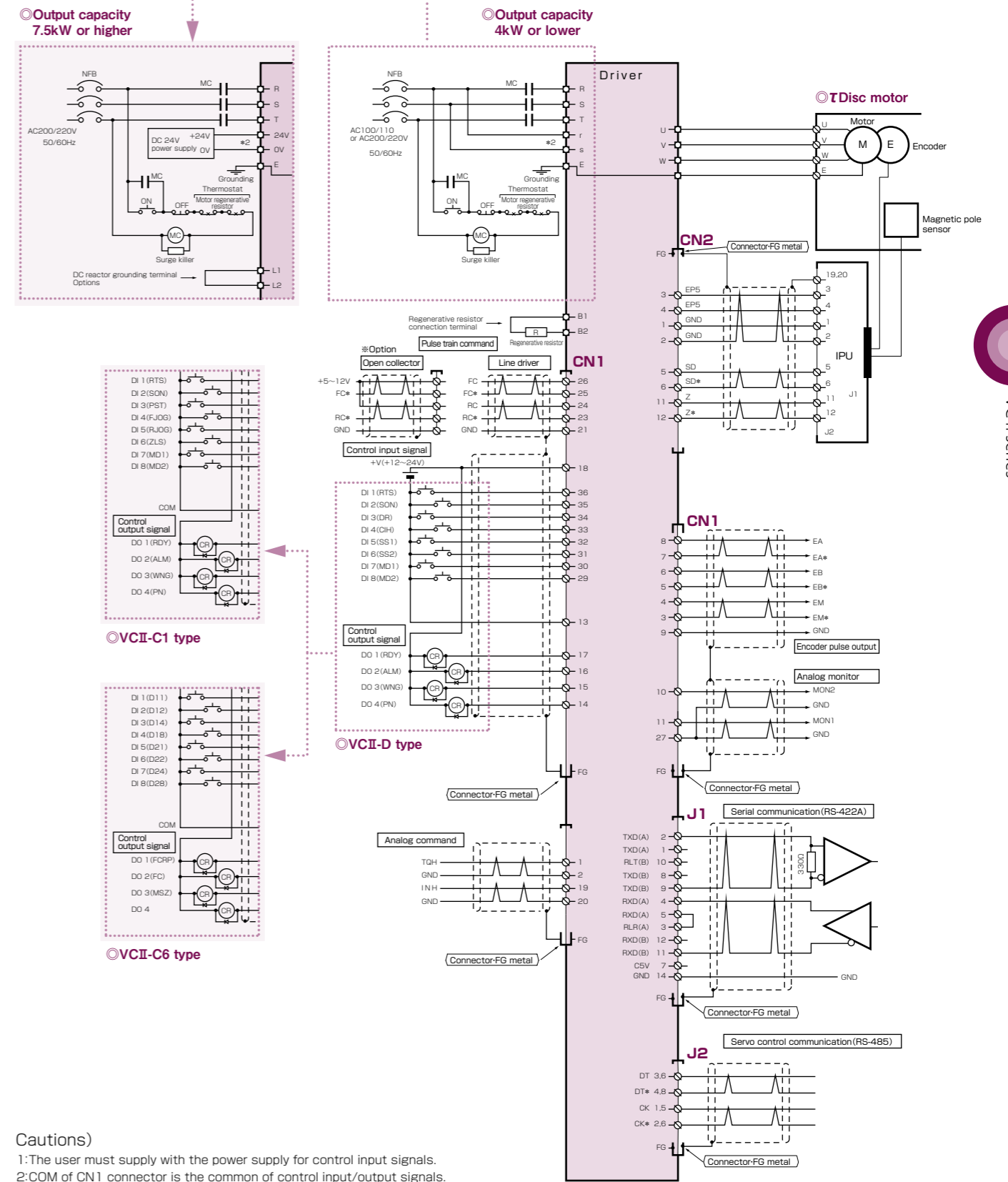

- Cautions)
- 1:The user must supply with the power supply for control input signals.
 - 2:COM of CN1 connector is the common of control input/output signals.
GND is the common of inner control power source (5V) in the device.
 - 3:Common wiring should not be done because COM of CN1 and GND are isolated.
 - 4:The status of switch connected to the control input signals indicates the state of OFF of each input signals
 - 5:The pin not mentioned in this diagram is NC
 - 6:Please refer to the instruction manual of "VCI series options" if the user is using the control input/output expansion unit.
 - 7:GND of pulse train command should be connected in case of using the line receiver option.
 - 8:The initial value of is indicated in () of control input/output signals

VPS Series

AC Servo driver

I/O type / CC-Link type



VPS series with variety of functions.

Cost effective and easy to use servo driver.

I/O type and CC-Link interface installed type are in the line-ups.

7 points positioning and zero return functions are equipped as the standard.

Feed forward control function and Resonance control filter function are also equipped.

Model

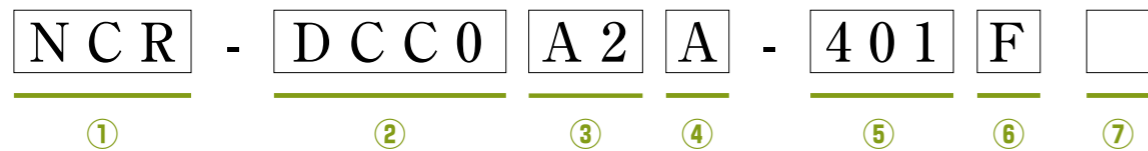

①	NCR··Nikki AC servo controller series	⑥	Motor combination -encoder	A··Synchronous AC servomotor NA80/800 series-serial encoder C··rlinear motor Separated interpolator unit specification D··rlinear motor Standard encoder E··rDISC motor Separated interpolator unit specification F··rDISC motor Standard encoder
②	Classification of Product	⑦	Special specifications	NON··Standard type S*··Special specifications
③	Input power source specifications			
④	Design order			
⑤	Output capacity			
	A1··AC100V A2··AC200V			
	A→B→C··Starting from A			
	Ex.)401··4 0 1 =40×10 ¹ =400w Exponent of accumulation of 10 Effective digit			

VPS Index

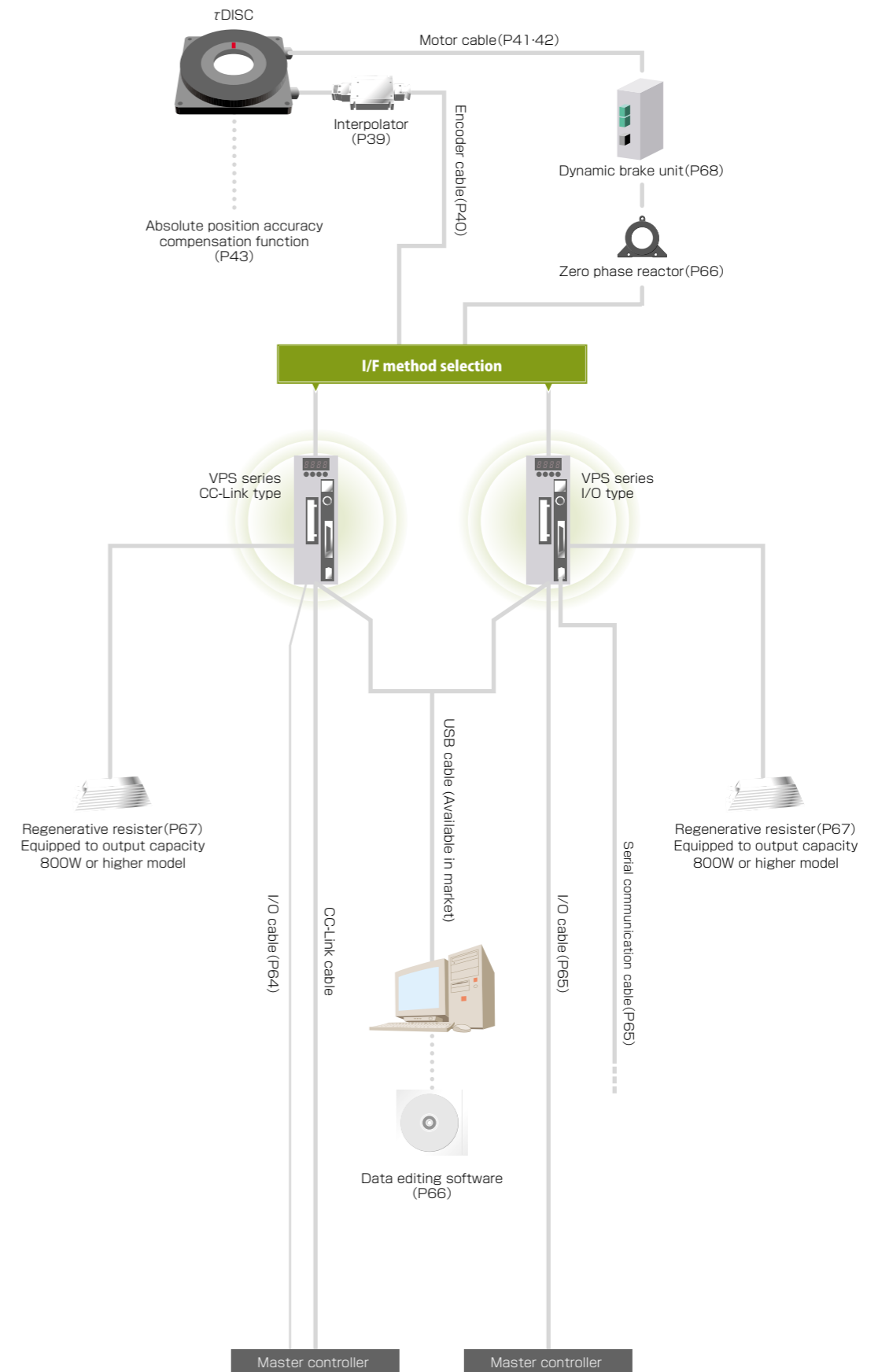

● VPS series Common specifications

Item		Specification
Ambient Condition	Temperature	Operating temperature 0~55°C Storage temperature -20~60°C ※
	Humidity	85% or lower, No condensation ※
	Installation location	No harmful substance such as corrosive gas, grinding fluid, metal powder, and oil are not allowed in the installation location.
	Altitude	1000m or lower
Cooling method		Capacity 800W or less : Natural air cooling, Capacity 1.6kw or more : Forced air cooling
Installation method		Panel installation type
Resistance to vibration		0.5G(10~50Hz)
Shock resistant		5G
Noise resistance	Line noise	2000V(50ns, 1μs), 1 minute
	Radiation noise	1000V(50ns, 10cm), 1 minute
	Electro-static noise	10kVA(between earth and case)

※Please avoid using at high temperature and high humidity conditions since the Life is heavily depended on the temperature and moisture.

● VPS series Special specifications

Item		Specification			
Model	NCR-□DA□A	1B-201□	2B-401□	2B-801□	2B-162□
Output capacity	W	200	400	800	1.6K
Input power supply	Voltage specifications	AC100~115, 50/60Hz single phase	AC200~230V, 50/60Hz single phase	AC200~230V, 50/60Hz 3-phase	
	Allowable voltage change	AC90~121V, 50/60Hz	AC180~242V, 50/60Hz	AC180~242V, 50/60Hz	
Drive method		3-phase sin wave PWM			
Power capacity (at rated output)	kVA	0.52	0.92	1.8	3.0
Continuous output current	Arms	3.5	3.5	6.8	10
Instant output current	Arms	8.75	8.75	17	30
Control method		Semi closed loop with encoder (linear sensor) feedback			
Brake method		Regenerative brake : regenerative resistor external installation			
Carrier frequency	kHz	10			
Speed control range ※1		1:2000			
Max speed frequency	Mpps	16			
No fuse breaker (Rated current) ※2	A	5	10	15	
Mass ※3	kg	約1.0	約1.5	約2.0	
Option		Regenerative resistor (Refer to P67)			

※1 When the load is 100%, the motor will be not stopped within the speed control range.

※2 Select a molded case circuit breaker which has appropriate interruption capacity for the power capacity to achieve protective coordination.

● VPS series Function specifications

Item		Specification	
Type		I/O Type(NCR-DCDO)	CC-Link Type(NCR-DCDO)
Number of control axis		1 axis	
Encoder feedback Input frequency		16Mpps(However, frequency of encoder pulse 4-multiplication)	
Operation mode		Speed control-Pulse train command	
Command input style	Pulse train command	①90-degree phase difference pulse ②Directional pulse ③Directional signal + sending pulse «Capable to meet Line driver output. Max. input is 4Mpps»	
	Analog command	Speed control run DC -10V~ +10V※1	-
	Internal command	Positioning (7points), Zero point return, Manual run, by internal pulse train command	
Major function		Speed control run, Pulse train run, Zero point return run, Manual (Jog) run, torque limit, Self-diagnosis, Electronic thermal, Auto tuning function	
Acceleration deceleration pattern		Linear accel-decel-S-letter accel-decel(Command averaging function use)	
Gain select function		Speed gain change 3 points(Normal, Slow-speed, GSEL-change)	
Control input signal (External input signal Basic 8 points) ※2		Start(DR), Servo ON(SON), Reset(RST), Mode-select(MD), Command pulse input prohibition(CIH), Emergency stop(EMG), Command select(SS1~3), Forward jog(FJ), Reverse jog(RJ), Zero point deceleration(ZLS), Forward over travel(FOT), Reverse over travel(ROT), Gain select(GSEL), Torque limit(TL), Internal pulse start(ZST), Zero point maker(ZMK), Command direction reverse(RVS), Command data reflection prohibition(NRF)	
		Present position data output request(APRQ) Alarm code output request(ALRQ) ABS data output request(ABRQ)	-
Output signal(Basic 4 points) ※2		Servo ready(RDY), Alarm(ALM), Deflection range A(PNA), Deflection range B(PNB), Speed zero(SZ), Brake release(BRK), Marker output(OCEM), Emergency stop onward(EMGO), Zero point return completed(HCP)	
Encoder pulse output		90° phase difference pulse train output(Division output possible: maximum output frequency of A/B-phase 2-signal is 7.99Mpps with 4-multiplication)	-
Operation/display function		By operating panel, it is possible to run status display, editing parameter and self-diagnosis.	
Filter function		Notch filter, Torque command filter	
Monitor function		①By data display LED (7 segment LED 4 digits), select and display Alarm, Frequency, Torque, Deviation rate, Speed command input, I/O signal and Parameter status. ②Various monitoring is enable with USB compatible exclusive editing software (option).	
Protective function		IPM error, Excessive voltage, Low voltage, Over speed, Overload (electronic thermal), Regenerative excessive current, Deviation over flow, RAM error, Encoder error, Magnetic pole detection error, DSP error, etc. Latest five alarm records can be indicated	
Communication function		Serial communication (RS-422A) or CC-Link enable various data transeiving	
		By USB (1.1/2.0 standard compliance), it can communicate with data editing software	

※1 In the range of -0.2V ~+0.2V, the accuracy in the relation between input voltage and motor speed is decreasing. The motor movement according to command value is not guaranteed in the operation at this range.

※2 Refer to P61-62 "external connection diagram" for initial value of external input/output 8/4 point signal.

It enables allocated input/output signal allocation or communication and CC-Link except initial value. For CC-Link, OCEM can do the external output only. The control input signal enables immobilization of the signal status.

When being assigned to the external output signal, signal logic change is possible (OCEM is excluded).

TDISC↔VPS series matching chart

■D series ↔VPS series with built-in Interpolator unit encoder matching chart

rDISC servo motor (D series)			Rated /Max torque when combined with servo driver(N·m)	Input Voltage (ACV)	VPS series		Dynamic brake unit	
Type	Frang type	Flange-less			I/O Type Model	CC-Link Type Model		
D110	40	NMR-FADBA2C-061A	NMR-FPDBA2B-061A	2 / 6	Single phase 100 Single phase 200	NCR-DCC0A1B-201F NCR-DCC0A2B-401F	NCR-XABCA2B-801-UL	
	60	NMR-FAEBA2C-121A	NMR-FPEBA2B-121A	4 / 12	Single phase 100 Single phase 200	NCR-DCC0A1B-201F NCR-DCC0A2B-401F		
D170	40	NMR-FDDBA2D-201A	NMR-FSDBA2C-201A	7.5 / 22.5	Single phase 100 Single phase 200	NCR-DCC0A1B-201F NCR-DCC0A2B-401F		
	100	NMR-FDFBA2C-701A	NMR-FSFBA2C-701A	22.5 / 67	3 phase 200	NCR-DCC0A2B-801F NCR-DCC0A2B-801F		
D250	40	NMR-FEDBA2C-401A	NMR-FTDBA2C-401A	20.7 / 51.75	Single phase 100 Single phase 200	NCR-DCC0A1B-201F NCR-DCC0A2B-401F		NCR-XABCA2B-222-UL
	100	NMR-FEFBA2C-122A	NMR-FTFBA2C-122A	62 / 186	3 phase 200	NCR-DCC0A2B-162F NCR-DCC0A2B-162F		
D400	40	NMR-FFDBA2C-801A	NMR-FUDBA2C-801A	67 / 134	3 phase 200	NCR-DCC0A2B-801F NCR-DCC0A2B-801F	NCR-XABCA2B-801-UL	

■D series ↔VPS series with external Interpolator unit (IPU) encoder matching chart

rDISC servo motor (D series)			Rated /Max torque when combined with servo driver(N·m)	Input Voltage (ACV)	VPS series		Dynamic brake unit	
Type	Frang type	Flange-less			I/O Type Model	CC-Link Type Model		
D110	40	NMR-FADBA2C-061A	NMR-FPDBA2B-061A	2 / 6	Single phase 100 Single phase 200	NCR-DCC0A1B-201E NCR-DCC0A2B-401E	NCR-XABCA2B-801-UL	
	60	NMR-FAEBA2C-121A	NMR-FPEBA2B-121A	4 / 12	Single phase 100 Single phase 200	NCR-DCC0A1B-201E NCR-DCC0A2B-401E		
D170	40	NMR-FDDBA2D-201A	NMR-FSDBA2C-201A	7.5 / 22.5	Single phase 100 Single phase 200	NCR-DCC0A1B-201E NCR-DCC0A2B-401E		
	100	NMR-FDFBA2C-701A	NMR-FSFBA2C-701A	22.5 / 67	3 phase 200	NCR-DCC0A2B-801E NCR-DCC0A2B-801E		
D250	40	NMR-FEDBA2C-401A	NMR-FTDBA2C-401A	20.7 / 51.75	Single phase 100 Single phase 200	NCR-DCC0A1B-201E NCR-DCC0A2B-401E		NCR-XABCA2B-222-UL
	100	NMR-FEFBA2C-122A	NMR-FTFBA2C-122A	62 / 186	3 phase 200	NCR-DCC0A2B-162E NCR-DCC0A2B-162E		
D400	40	NMR-FFDBA2C-801A	NMR-FUDBA2C-801A	67 / 134	3 phase 200	NCR-DCC0A2B-801E NCR-DCC0A2B-801E	NCR-XABCA2B-801-UL	

■HD series ↔VPS series with built-in Interpolator unit encoder matching chart

rDISC servo motor (HD series)			Rated /Max torque when combined with servo driver(N·m)	Input Voltage (ACV)	VPS series		Dynamic brake unit
Type	Frang type	Flange-less			I/O Type Model	CC-Link Type Model	
D140	160	NMR-FCHBA2D-661A	NMR-FRIHBA2D-661A	21 / 58.8	3 phase 200	NCR-DCC0A2B-801F NCR-DCC0A2B-162F	NCR-XABCA2B-801-UL NCR-XABCA2B-222-UL
	185	NMR-FCIBA2D-751A	NMR-FRIBA2D-751A	24 / 67.2		NCR-DCC0A2B-162E NCR-DCC0A2B-162E	

■HD series ↔VPS series with external Interpolator unit (IPU) encoder matching chart

rDISC servo motor (HD series)			Rated /Max torque when combined with servo driver(N·m)	Input Voltage (ACV)	VPS series		Dynamic brake unit
Type	Frang type	Flange-less			I/O Type Model	CC-Link Type Model	
D140	160	NMR-FCHBA2D-661A	NMR-FRIHBA2D-661A	21 / 58.8	3 phase 200	NCR-DCC0A2B-801E NCR-DCC0A2B-162E	NCR-XABCA2B-801-UL NCR-XABCA2B-222-UL
	185	NMR-FCIBA2D-751A	NMR-FRIBA2D-751A	24 / 67.2		NCR-DCC0A2B-162E NCR-DCC0A2B-162E	

■ND-c series ↔ VPS series with built-in Interpolator unit encoder matching chart

rDISC servo motor (ND-c series)			Rated /Max torque when combined with servo driver(N·m)	Input Voltage (ACV)	VPS series		Dynamic brake unit
Type	Model (Incremental)	Model (Absolute)			I/O Type Model	CC-Link Type Model	
ND110	65-C	NMR-CAEIA2A-071A	-	2.4 / 7.2	Single phase 100 Single phase 200	NCR-DCC0A1B-201F NCR-DCC0A2B-401F	NCR-XABCA2B-801-UL
	85-C	NMR-CAUIA2A-151A		4.8 / 12	Single phase 100 Single phase 200	NCR-DCC0A1B-201F NCR-DCC0A2B-401F	
ND140	70-C	NMR-CREIA2A-151A	4.8 / 14.4	Single phase 100 Single phase 200	NCR-DCC0A1B-201F NCR-DCC0A2B-401F		
	95-C	NMR-CRFIA2A-311A	9.6 / 28.8	3 phase 200	NCR-DCC0A2B-801F NCR-DCC0A2B-801F		
ND180	70-C	NMR-CSMIA2A-281A	9 / 27		3 phase 200	NCR-DCC0A2B-401F NCR-DCC0A2B-401F	
	95-C	NMR-CSEIA2A-561A	18 / 54	3 phase 200		NCR-DCC0A2B-801F NCR-DCC0A2B-801F	
ND250	70-C	NMR-CTEIA2A-501A	27 / 81		3 phase 200	NCR-DCC0A2B-801F NCR-DCC0A2B-801F	
	95-C	NMR-CTFIA2A-841A	45 / 112.5	3 phase 200		NCR-DCC0A2B-801F NCR-DCC0A2B-801F	
ND400	70-C	NMR-CUEIA2A-951A	76 / 190		3 phase 200	NCR-DCC0A2B-801F NCR-DCC0A2B-801F	

■ND-c series ↔ VPS series with external Interpolator unit (IPU) encoder matching chart

rDISC servo motor (ND-c series)			Rated /Max torque when combined with servo driver(N·m)	Input Voltage (ACV)	VPS series		Dynamic brake unit
Type	Model (Incremental)	Model (Absolute)			I/O Type Model	CC-Link Type Model	
ND110	65-C	NMR-CAEGA2A-071A	NMR-CAEHA2A-071A	2.4 / 7.2	Single phase 100 Single phase 200	NCR-DCC0A1B-201E NCR-DCC0A2B-401E	NCR-XABCA2B-801-UL
	85-C	NMR-CAUGA2A-151A	NMR-CAUHA2A-151A	4.8 / 12	Single phase 100 Single phase 200	NCR-DCC0A1B-201E NCR-DCC0A2B-401E	
ND140	70-C	NMR-CREGA2A-151A	NMR-CREHA2A-151A	4.8 / 14.4	Single phase 100 Single phase 200	NCR-DCC0A1B-201E NCR-DCC0A2B-401E	
	95-C	NMR-CRFGA2A-311A	NMR-CRFHA2A-311A	9.6 / 28.8	3 phase 200	NCR-DCC0A2B-801E NCR-DCC0A2B-801E	
ND180	70-C	NMR-CSMGA2A-281A	NMR-CSMHA2A-281A	9 / 27		3 phase 200	
	95-C	NMR-CSEGA2A-561A	NMR-CSEHA2A-561A	18 / 54	3 phase 200		
ND250	70-C	NMR-CTEGA2A-501A	NMR-CTEHA2A-501A	27 / 81		3 phase 200	NCR-DCC0A2B-801E NCR-DCC0A2B-801E
	95-C	NMR-CTFGA2A-841A	NMR-CTFHA2A-841A	45 / 112.5	3 phase 200		NCR-DCC0A2B-801E NCR-DCC0A2B-801E
ND400	70-C	NMR-CUEGA2A-951A	NMR-CUEHA2A-951A	76 / 190		3 phase 200	NCR-DCC0A2B-801E NCR-DCC0A2B-801E

■ND series ↔VPS series matching chart

rDISC servo motor (ND series)			Rated /Max torque when combined with servo driver(N·m)	Input Voltage (ACV)	VPS series		Dynamic brake unit
Type	Model (Incremental)	Model (Absolute)			I/O Type Model	CC-Link Type Model	
ND110	50	NMR-NAMBA2A-071A	-	2.4 / 7.2	Single phase 100 Single phase 200	NCR-DCC0A1B-201F NCR-DCC0A2B-401F	NCR-XABCA2B-801-UL
	100	NMR-NPEBA2A-201A	-	7 / 17.5	Single phase 200	NCR-DCC0A2B-401F NCR-DCC0A2B-401F	
ND180	55	NMR-NAMGA2A-201A	-	9 / 27	Single phase 100 Single phase 200	NCR-DCC0A1B-201E NCR-DCC0A2B-401E	NCR-XABCA2B-222-UL
	110	NMR-NSFGA2B-701A	-	27 / 81	3 phase 200	NCR-DCC0A2B-162E NCR-DCC0A2B-162E	
ND250	55	NMR-NEMGA2B-401A	NMR-NEMHA2B-401A	21.5 / 53.75	Single phase 100 Single phase 200	NCR-DCC0A2B-401E NCR-DCC0A2B-401E	NCR-XABCA2B-801-UL
	110	NMR-NTFGA2B-122A	NMR-NTFHA2B-122A	27 / 81	3 phase 200	NCR-DCC0A2B-801E NCR-DCC0A2B-801E	
ND400	55	NMR-NFMGA2B-801A	NMR-NFMHA2B-801A	67 / 187.6	3 phase 200	NCR-DCC0A2B-162E NCR-DCC0A2B-162E	NCR-XABCA2B-222-UL NCR-XABCA2B-801-UL
	55	NMR-NFMGA2B-801A	NMR-NFMHA2B-801A	76 / 190	3 phase 200	NCR-DCC0A2B-801E NCR-DCC0A2B-801E	

VPS series Dimensions

○NCR-DC□0A1*-201□/A2*-401□

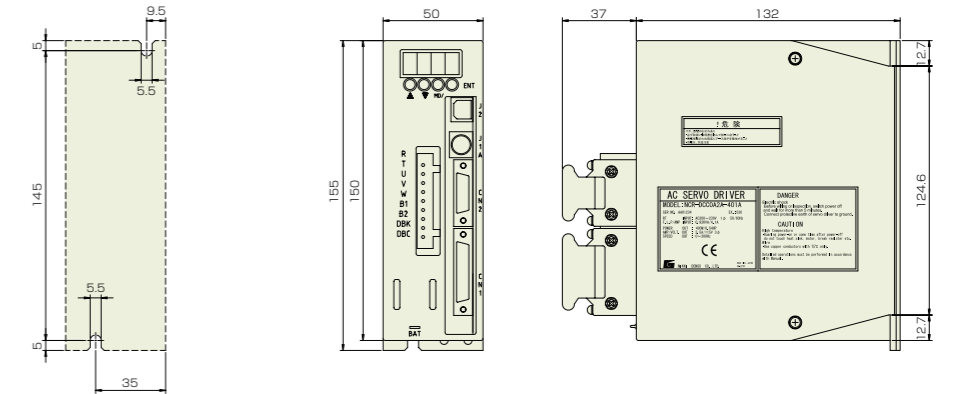

○NCR-DC□0A2*-801□

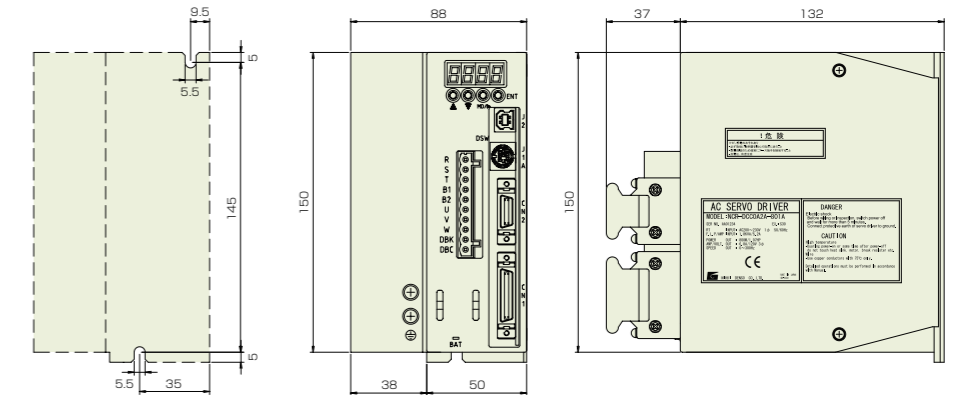

○NCR-DC□0A2*-162□

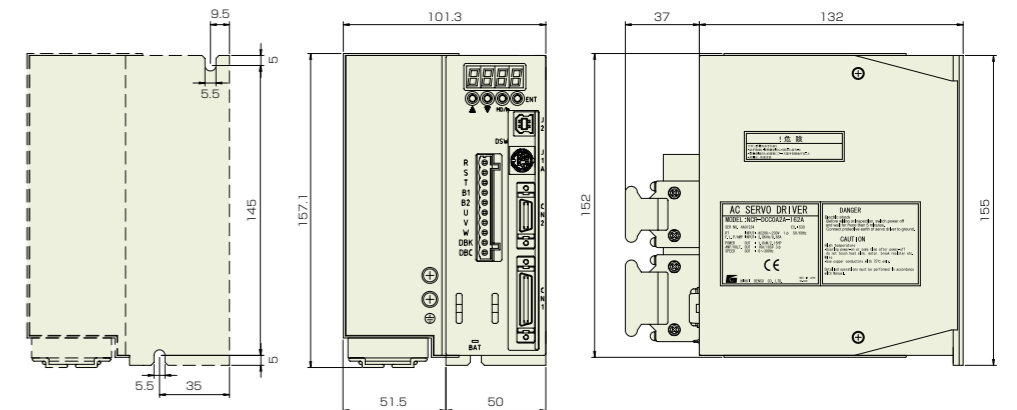

* Indicated dimensions are I/O type (same size as CC-Link type)

● Specifications and the external connection diagram for VPS series with the built-in interpolator encoder

P-1

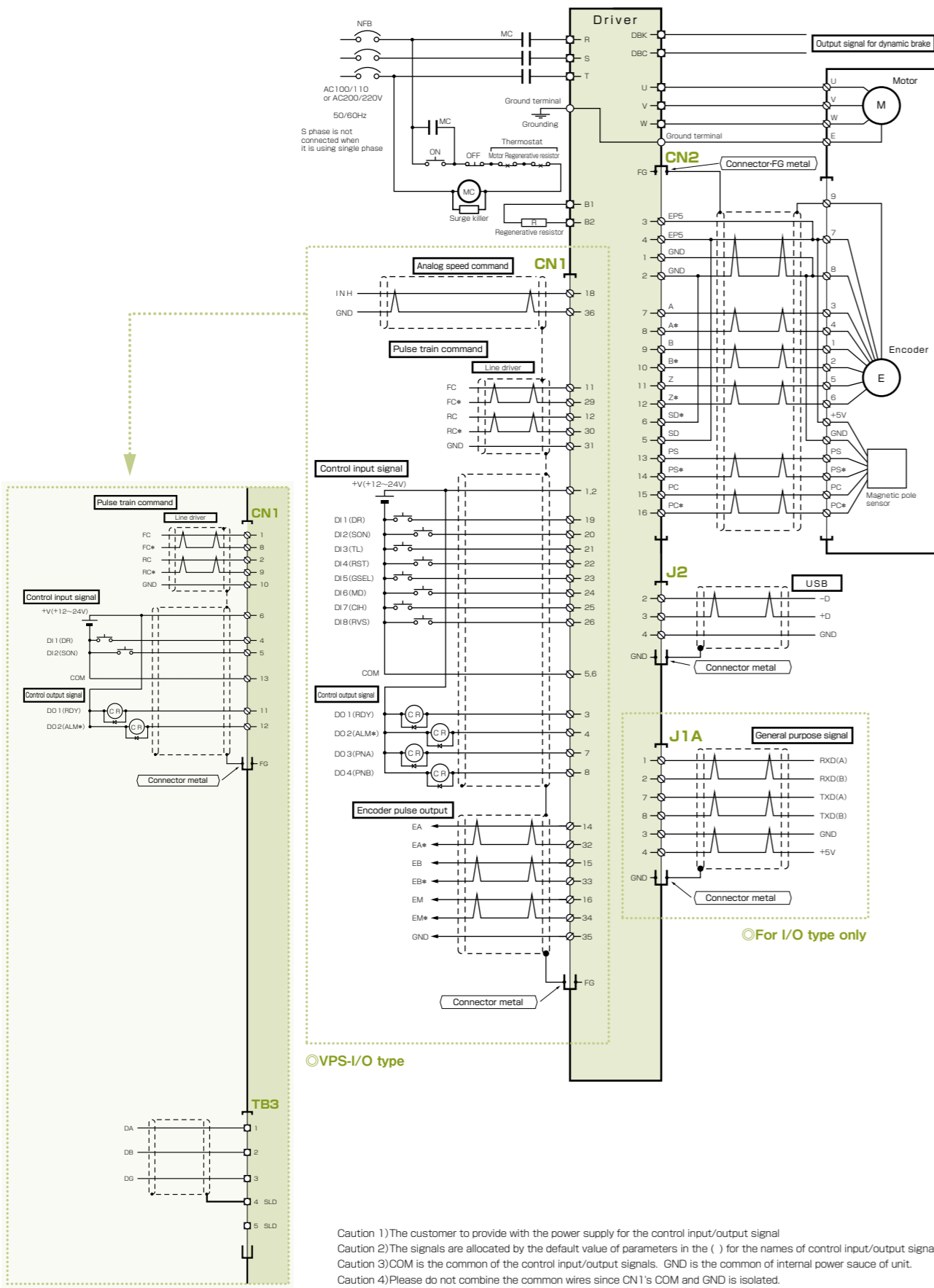

● Specifications and the external connection diagram for VPS series with the separated interpolator (IPU) encoder

P-2

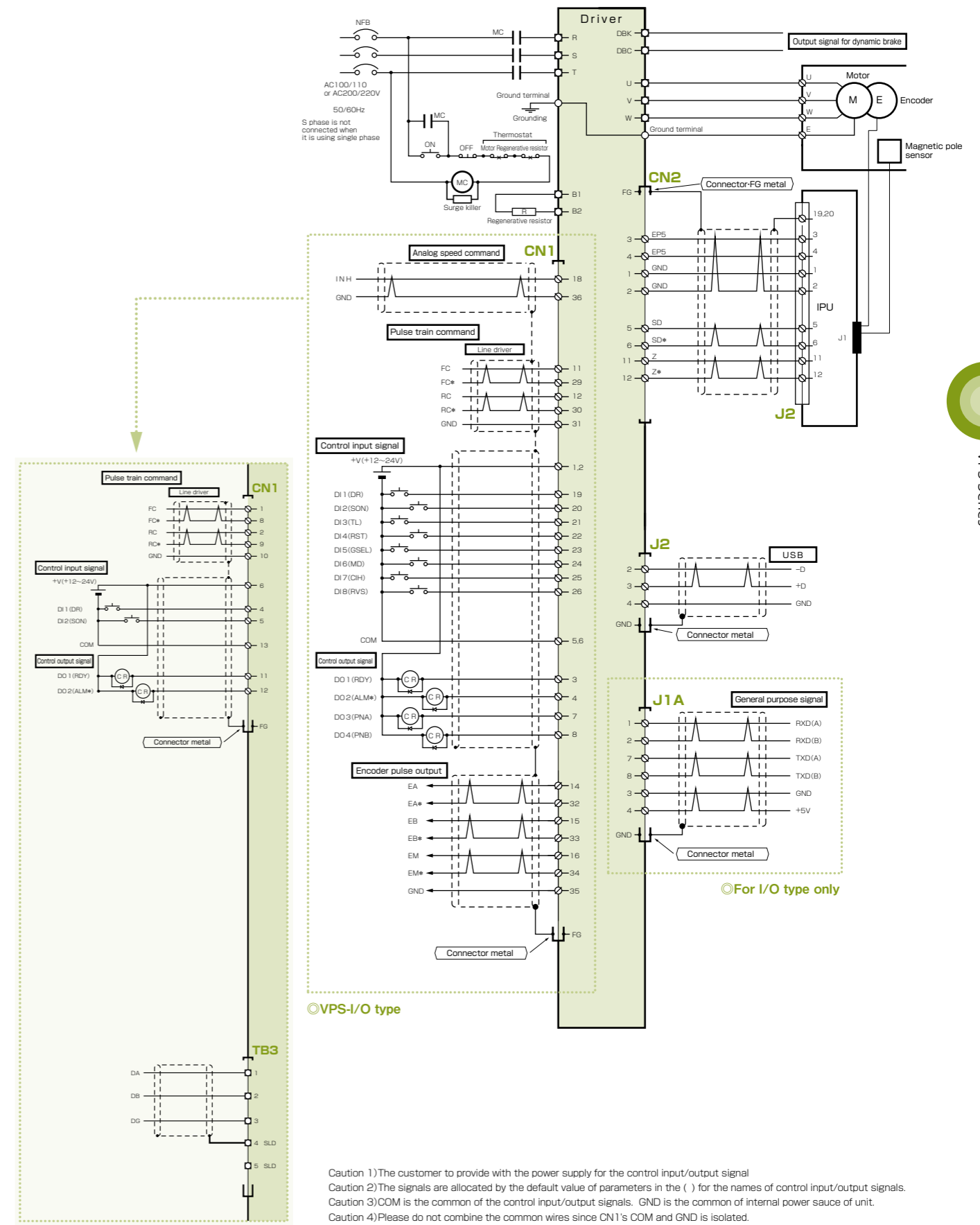

I/O connection (VCI series)

VCII unit I/O cable VCIC series

Model	Cable length (mm)
NCR-XBA1A-010	1000±30
NCR-XBA1A-020	2000±30
NCR-XBA1A-030	3000±30

VCIC series is the I/O cable to connect to the control input/output connector (CN-1) of VCI and to input/output each signals.

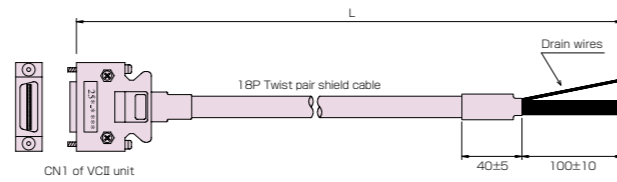

VCII unit I/O terminal cable VCTC series

Model	Cable length (mm)
NCR-XBA2A-010	1000±30
NCR-XBA2A-020	2000±30
NCR-XBA2A-030	3000±30

VCTC series is the I/O terminal cable to connect to the control input/output connector (CN-1) of VCI unit to I/O terminal unit (40 poles)

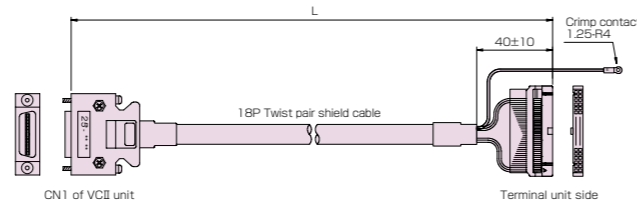

I/O terminal unit (screw type)

Model	No. of terminal	L1 (mm)	L2 (mm)	connection
ZTB-400	40 poles	203	193	VCI unit
ZTB-200	20 poles	118	108	control input/
ZTB-500	50 poles	245	235	output expansion unit

The unit is the terminal unit to exchange input connector. The connection type is screw type. For connecting to VCI, it needs special I/O terminal unit cable (VCTC series).

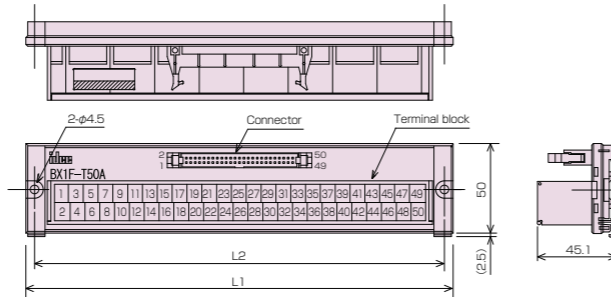

I/O terminal unit (cage clamp type)

Model	No. of terminal	L (mm)	connection
NCR-XABND3A	40 poles	77	VCI unit
NCR-XABMD3A	20 poles	52	control input/
NCR-XABSD3A	50 poles	95	output expansion unit

The unit is the terminal unit to exchange input connector. The connection type is cage clamp type. For connecting to VCI, it needs special I/O terminal unit cable (VCTC series).

■ Cage clamp type common terminal

Model	No. of terminal	L (mm)
NCR-XABQD3A	8x2	38

Please use it when it is necessary to connect 2 or more cables to a terminal.

■ Driver for operation

Model
NCR-XABRDOA

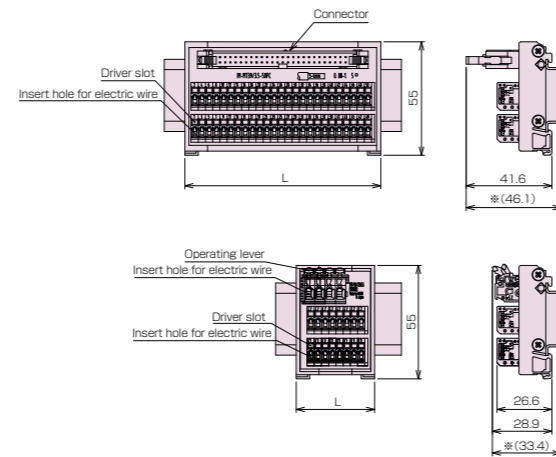

※The size when DIN35mm rail is installed.

I/O signal connector kit CSZ-INF

Model
CSZ-INF

CSZ-INF is the connector kit for control input/output connector (CN1) of VCI series

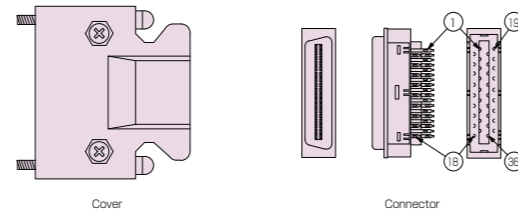

I/O connection (VCI series)

Input/output cable for the control input/output expansion unit VCFIC series

Model	Cable length (mm)
NCR-XBA3A-010	1000±30
NCR-XBA3A-020	2000±30
NCR-XBA3A-030	3000±30

The cables to connect VCI series servo driver options and connect to the control output/input expansion board connector (CN3) to input and output each signals.

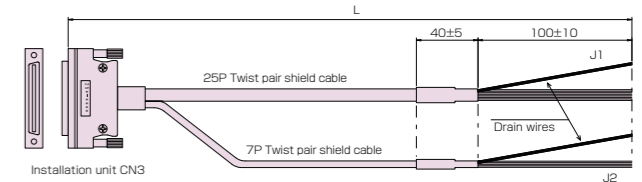

I/O terminal cable for the control input/output expansion unit FTTC series

Model	Cable length (mm)
FTTC-010	1000
FTTC-020	2000
FTTC-030	3000

The connection cable for CN3 connector of control input/output expansion unit and I/O terminal unit (50 poles, 20 poles)

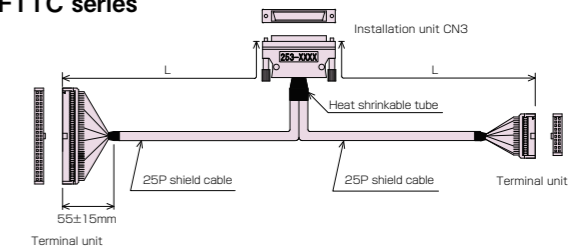

I/O connection (VPS series)

I/O type I/O cable ZIC series

Model	Cable length (mm)
ZIC-020	2000±50
ZIC-030	3000±30

ZIC series is the connection cable for I/O signal (CN-1) of VPS series servo driver I/O type

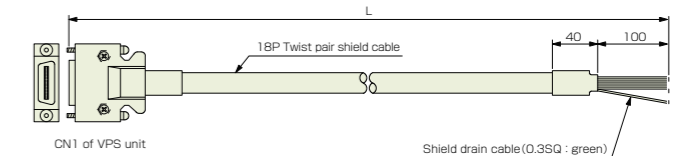

I/O terminal cable ZTTC series

Model	Cable length (mm)
ZTTC-010	1000±30
ZTTC-030	3000±50

ZTTC series is the connection cable for I/O signal (CN1) of VPS series servo driver I/O type to connect with the terminal unit (40 poles)

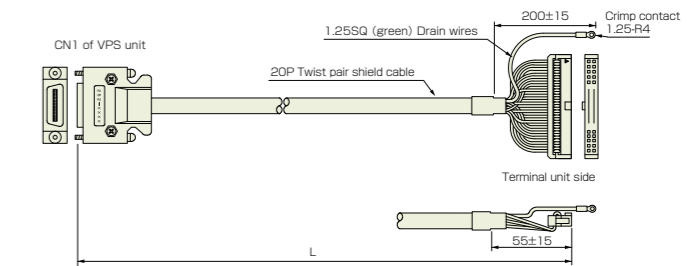

I/O terminal unit (screw type)

Model	No. of terminal	L1 (mm)	L2 (mm)
ZTB-400	40 poles	203	193

The unit is the terminal unit to exchange input connector. The connection type is screw type. For connecting to VPS, it needs special I/O terminal unit cable (ZTTC series).

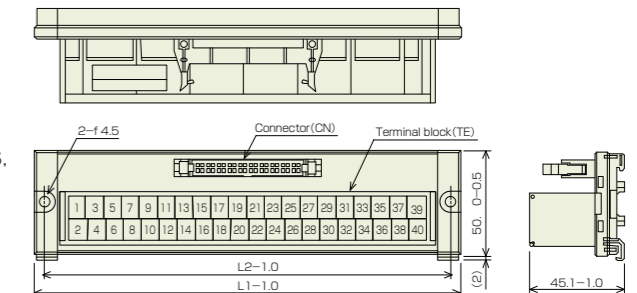

I/O terminal unit (cage clamp type)

Model	No. of terminal	L (mm)
NCR-XABND3A	40 poles	77

The unit is the terminal unit to exchange input connector. The connection type is cage clamp type. For connecting to VPS, it needs special I/O terminal unit cable (ZTTC series).

■ Cage clamp type common terminal

Model	No. of terminal	L (mm)
NCR-XABQD3A	8x2	38

Please use it when it is necessary to connect 2 or more cables to a terminal.

■ Driver for operation

Model
NCR-XABRDOA

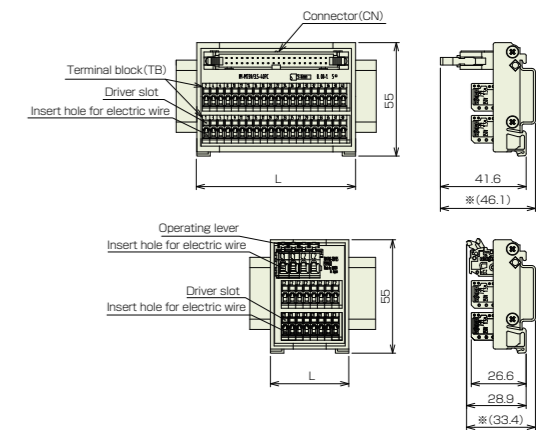

※The size when DIN35mm rail is installed.

I/O connection(VPS series)

I/O type I/O signal connector kit CSZ-INF

Model
CSZ-INF

CSZ-INF is the connector kit to connect I/O signal (CN-1) of VPS series servo driver I/O type.

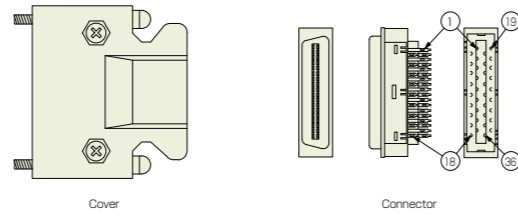

CC-Link type I/O cable VPIC series

Model	Cable length(mm)
NCR-XBA5A-010	1000±30
NCR-XBA5A-020	2000±30
NCR-XBA5A-030	3000±30

VPIC series is the connection cable for I/O signal (CN-1) of VPS series servo driver with CC-Link unit.

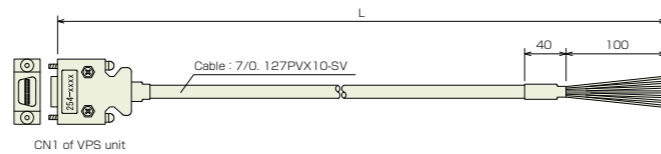

ZCK-COM : CC-Link type I/O signal connector kit

Model
ZCK-COM

ZCK-COM is the connector kit for connecting I/O signal (CN1) of VPS series-CC-Link.

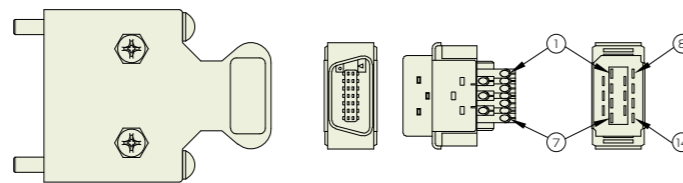

Serial communication(VCII/VPSseries)

Communication cable for RS-232C

Model	Cable length(mm)
NCR-XBF1A-010	1000±30
NCR-XBF1A-030	3000±50
NCR-XBF1A-050	5000±100
NCR-XBF1A-100	10000±100

The communication cable is for inputting and outputting each data from RS232 to VCIIseries servo driver.

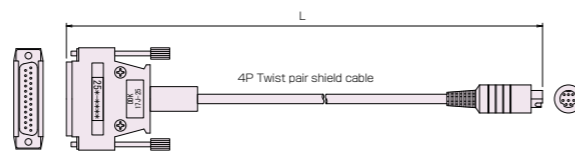

※Caution

※When connecting to PC, please supply DOS/V PC D-sub 25 pin (Female) <=>9 pin (Female) straight type exchange adapter. In case of using USB, please supply USB-Serial exchange cable.

Communication cable for RS-422C

Model	Cable length(mm)
NCR-XBF5A-010	1000±30
NCR-XBF5A-030	3000±50
NCR-XBF5A-050	5000±100
NCR-XBF5A-100	10000±100

The communication cable is for inputting and outputting each data from RS422 to VCII series servo driver.

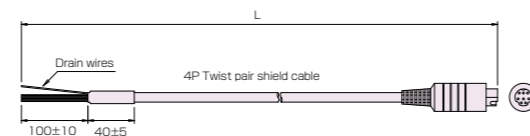

Serial communication connector kit

Model
NCR-XBDPA

NCR-XBDPA is the connector kit to RS-422 serial communication (J1) of VCIIseries.

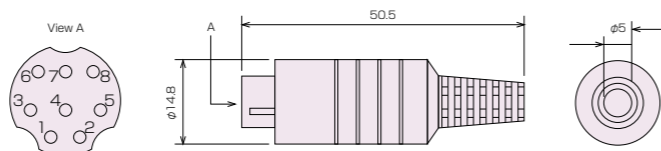

Other option(VCII series)

SDI device

Model
NCR-XAA1D1B

Data input unit of servo controller 800W or lower for inputting parameters and data. Also, it works as data display unit to show the status of controller.

※The built-in device is installed for VCII series 1.5kW or higher.

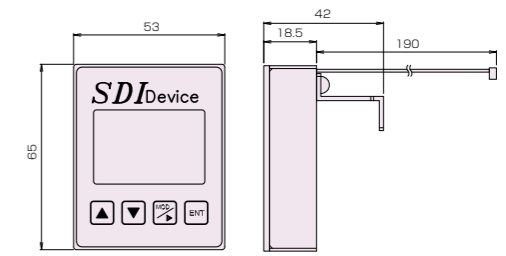

Synchronous communication cable SHCC series

Model	Cable length (mm)
SHCC-005	500
SHCC-010	1000
SHCC-030	3000

The cable for synchronous operation of VCII series.

The synchronous communication terminal resistance SHCC-R to be connected to the each cable ends.

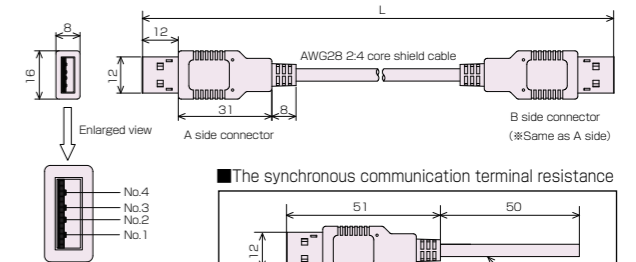

■The synchronous communication terminal resistance

Model	References
SHCC-R	2 pcs/set

Noise prevention options(VCII/VPS series)

Zero phase reactor (For common mode)

Model
NCR-XAB4A
NCR-XAB5A

Reduce the noise generated by servo driver and lower the noise influence to the peripheral devices.

Caution : Please consider the wiring and grounding method since it may affect the performance.

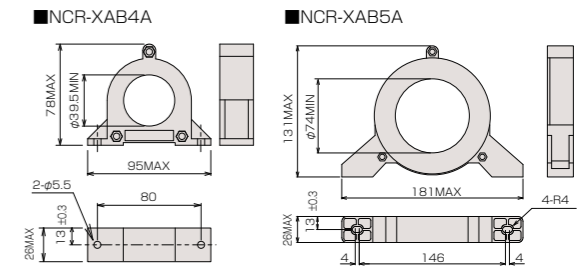

■In regard of the number of zero phase reactor

●The relation between power size AWG (mm²) and Zero phase reactor

Zero phase reactor	inner diameter	Power size AWG(mm ²)	
		18~10(0.75~5.5)	8~6(8.0~14.0)
NCR-XAB4A	39.5mm	3~5 turn 1 unit	3~5 turn 1 unit
NCR-XAB5A	74.0mm	3~5 turn 1 unit	3~5 turn 1 unit

This diagram is calculated based on the size of AWG (mm²) of MLFC cable (600V, 110°C) and the zero phase reactor. This diagram may be used as the guide line since the diameter and stiffness of wires to be used are all different. Recommended wrapping method: Wrap at least 3 to 5 times.

■Installation sample

●wire wrapping method

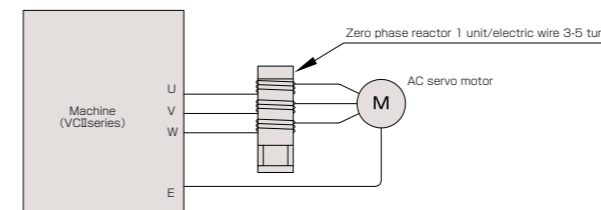

●wire glands method

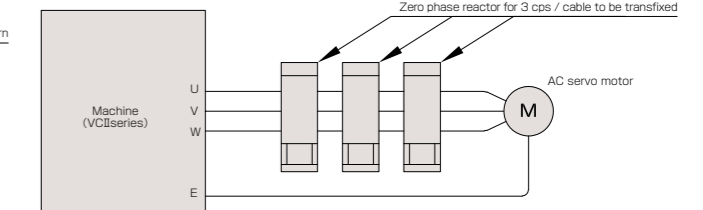

Ferrite core NCR-XAA9A for noise prevention

Model
NCR-XAA9A

For the prevention of malfunction (interruption of monitor display, shut down of data editing software, etc).

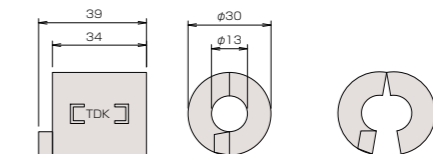

Data editing soft (VCII/ VPSseries)

Corresponding driver	Model	
	Japanese	English
VCIIseries	NCR-XCM000	NCR-XCN000
VPS series	NCR-XCB000	NCR-XCE000

Data editing software has the functions which are to edit VCII/VPS series servo driver from PC. Editing parameter, program, editing indirect data (only VCII-C1,C6 type), measuring and display of oscilloscope data, Remote run, self-diagnosis and so on.

● Regenerative resistor (Attachment)

Servo driver/controller model	Optional regenerative resistor type			
	Model	Specification/Figure	Dimension	
VCI series	NCR-□DA□A1A-101□	None ※		
	NCR-□DA□A1A-201□	None ※		
	NCR-□DA□A2A-201□	None ※		
	NCR-□DA□A2A-401□	None ※		
	NCR-□DA□A2A-801□	CAN60UT 82 ohm J	60W 82Ω×1	cement resistor Dimension A-1
	NCR-□DA□A2A-152□/222□	CAN200UT 24 ohm J	200W 24Ω×1	cement resistor Dimension A-2
	NCR-□DA□A2A-402□	CAN400UR 20 ohm J	400W 20Ω×1	cement resistor Dimension A-3
	NCR-□DA□A2A-752□	RGH-300-OS30J	300W 30Ω×3(Parallel connection Total 900W 10.0Ω)	Enamel resistor Dimension B-1
	NCR-□DA□A2A-113□	RGH-500-OS22J	500W 22Ω×3(Parallel connection Total 1.5kW 7.3Ω)	Enamel resistor Dimension B-2
	NCR-□DA□A2A-153□	RGH-500-OS22J	500W 22Ω×4(Parallel connection Total 2.0kW 5.5Ω)	Enamel resistor Dimension B-2
NCR-□DA□A2A-203□	RGH-500-OS22J	500W 22Ω×6(Parallel connection Total 3.0kW 3.7Ω)	Enamel resistor Dimension B-2	
VPS series	NCR-DC□OA1B-201□	None ※		
	NCR-DC□OA2B-401□	None ※		
	NCR-DC□OA2B-801□	CAN60UT 82 ohm J	60W 82Ω×1	cement resistor Dimension A-1
	NCR-DC□OA2B-162□	CAN200UT 39 ohm J	200W 39Ω×1	cement resistor Dimension C

※ When regenerative resistor is needed, we can supply CAN60UT82ohmJ(60W/82Ω/1unit) as an option.

◎ Regenerative resistor dimension

It indicates the dimension of regenerative resistor and mounting position of thermostat.

■ Dimension A-1-2-3

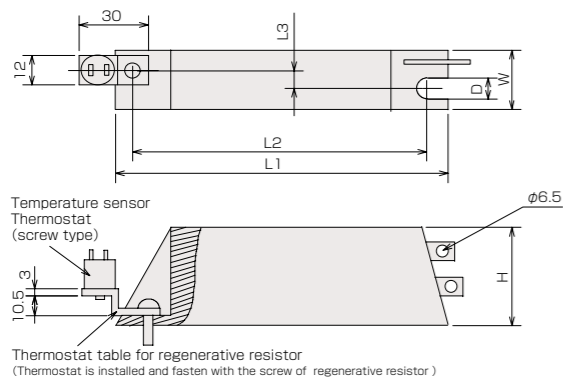

Dimension	Model	Rated	L1	L2	W	H	L3	D
Dimension A-1	CAN60	60W	115	100	20	40	5	4.3
Dimension A-2	CAN200	200W	215	200	26	50	8	5.3
Dimension A-3	CAN400	400W	265	250	33	61	13	5.3

■ Dimension B-1-2

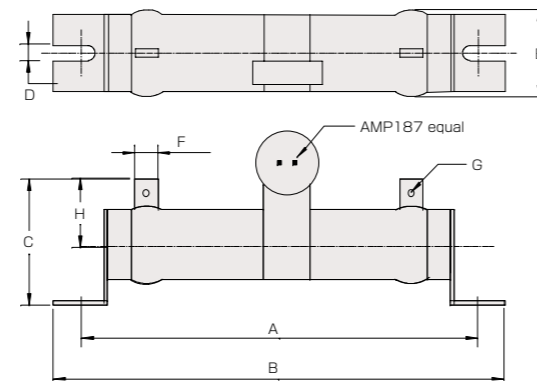

Dimension	Model	Rated	A	B	C	D	E	F	G	H
Dimension B-1	RGH300	300W	304	334	84	10	46	13	6.0	44
Dimension B-2	RGH500	500W	350	380	99	10	57	13	6.0	49

■ Dimension C

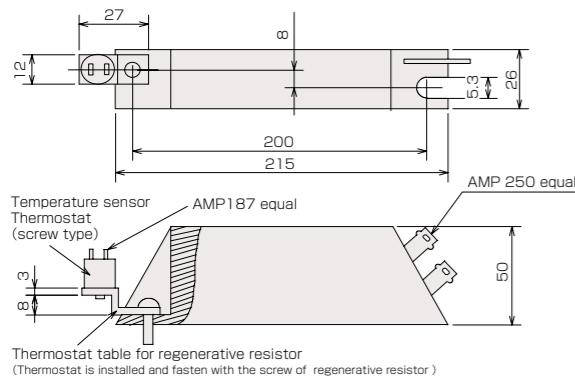

● Dynamic brake unit (Option)

Dynamic brake unit is the supplement unit of servo driver to slow down the motor. It prevents the connected motor to fail in the "free-run" situation when error or electric power failure is occurred.

◎ Dynamic brake unit dimensions

■ NCR-XABCA2B-801-UL Model

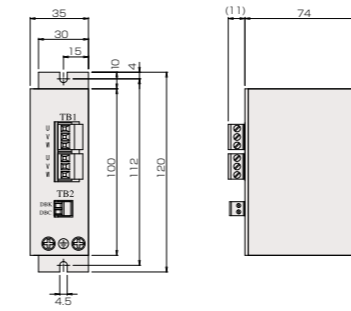

■ NCR-XABCA2B-222-UL Model

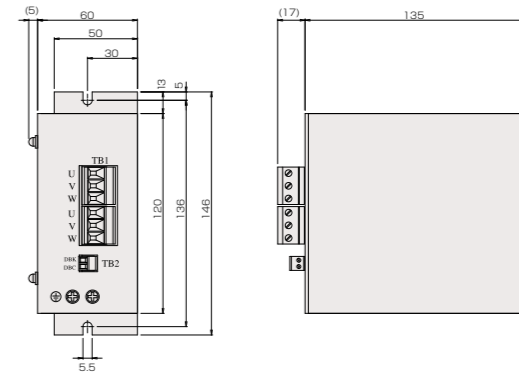

■ NCR-XABCA2B-402-UL Model

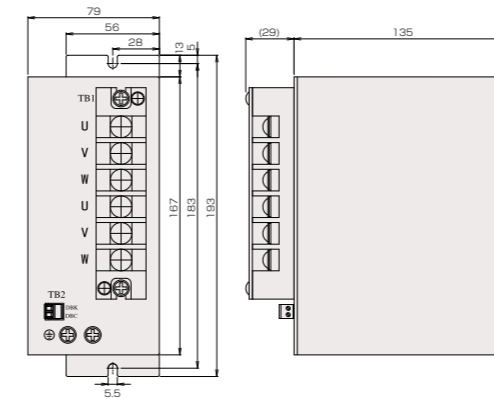

■ NCR-XABCA2B-752-UL Model NCR-XABCA2B-113-UL Model

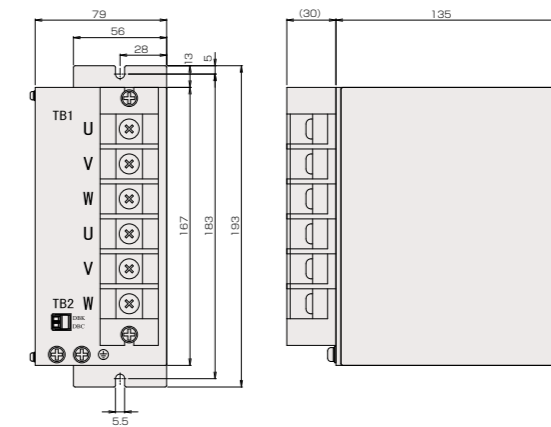

※ Please refer to P.49~50 (VCI driver), P.59~60 (VPS driver) for the combination of rDISC motor and servo driver.

● T DISC servomotor selection by index positioning of rotating object



This calculation formula is based on theoretical formula for your references only and it does not guarantee the result of selected value. Please review and understand that this calculation formula would be suitable before use it.

○How to select

You may select the τDISC servomotor by follow the instructions in the below :

Caution : The calculated value is for references only.

The value mentioned in the below is for general, and it is not absolute value.

1 Motion specifications, Movement pattern, the confirmation of load specifications

○Following items must be clarified.

Traveling angle..... s [°]
 Positioning speed..... t0 (sec)
 Cycle time..... t1 (sec)
 Load inertia moment..... JL (kg·m²)

2 Motor selection

○For τDISC servomotor, the target load inertia moment should be (Jm)×30(※)≤ Load inertia moment.

※The multiplying factor may be different depend on the movement specifications.

For the high speed positioning, it should be less than 3 times.

Due to the movement or specifications of machine, it often has to correspond for 300 times.

Please consult with our Sales Dept. for details.

Trial selection of τDISC servomotor specifications

Rated speed..... N (rps)
 Rated torque..... Tm (N·m)
 Peak torque..... Tpm (N·m)
 Rotor inertia..... Jm (kg·m²)

3 Calculating the acceleration and deceleration time

○Figure out the acceleration /deceleration time by using the formula in the below.

$$\text{Acceleration time reaching to the rated speed} \rightarrow t_2 = \frac{(Jm+JL) \times 2\pi N}{T_{pm} - TL} \times k \text{ (sec)}$$

k.....Safe margin(1.5 for common)

TL.....Total of Load torque by external force and torque loss(Loss from pressurizing the motor bearing, etc.)
 (Usual torque loss should be considered as 10% of the rated torque)

N E X T

From last page

4

Calculation of positioning speed

○Figure out the positioning speed by using the formula in the below.

■In case of $t_2 \times N \times 360 \leq s$

$$\text{Positioning speed} \rightarrow t_3 = \frac{s}{360 \times N} + t_2 + t_4 + t_5 \text{ (sec)}$$

t4.....Processing time at start
 Usually 0.005 sec.
 (For high shot requirement, please consider)

t5.....Settle time
 The target should be around the acceleration time(t2).
 It may differ depend on the required positioning accuracy.
 Also, it may be affected by the mechanical rigidity, and the value is not absolute

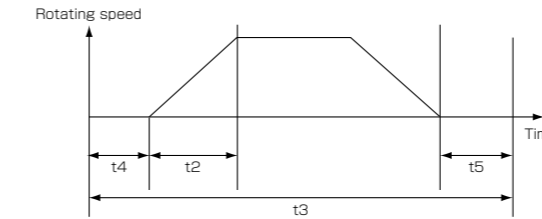

■In case of $t_2 \times N \times 360 > s$

$$\text{Acceleration time} \rightarrow t_{2a} = \sqrt{\frac{s \times t_2}{360 \times N}} \times k \text{ (sec)}$$

$$\text{Positioning speed} \rightarrow t_3 = t_{2a} \times 2 + t_4 + t_{5a} \text{ (sec)}$$

t5a.....Settle time
 The target should be around the acceleration time(t2a).
 It may differ depend on the required positioning accuracy.
 Also, it may be affected by the mechanical rigidity, and the value is not absolute

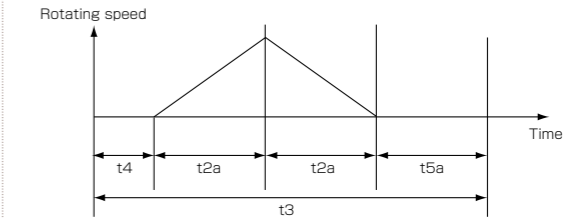

5

Calculating the effective torque

○Figure out the effective torque by using the formula in the below.

$$\text{Acceleration torque} \rightarrow t_p = \frac{2\pi N \times (Jm+JL)}{t_2} + TL \text{ (N·m)}$$

$$\text{Deceleration torque} \rightarrow t_b = \frac{2\pi N \times (Jm+JL)}{t_2} - TL \text{ (N·m)}$$

■In case of $t_2 \times N \times 360 \leq s$

$$\text{Constant speed} \rightarrow t_6 = \frac{s}{360 \times N} - t_2 \times 2 \text{ (sec)}$$

$$\text{Effective torque} \rightarrow t_{rms} = \sqrt{\frac{t_p \times t_2 + t_L \times t_6 + t_b \times t_2}{t_1}} \text{ (N·m)}$$

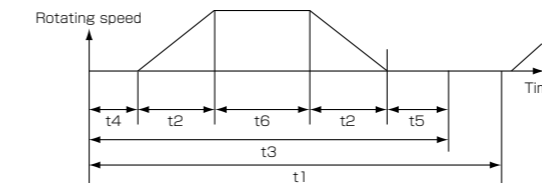

■In case of $t_2 \times N \times 360 > s$

$$\text{Effective torque} \rightarrow t_{rms} = \sqrt{\frac{t_p \times t_{2a} + t_b \times t_{2a}}{t_1}} \text{ (N·m)}$$

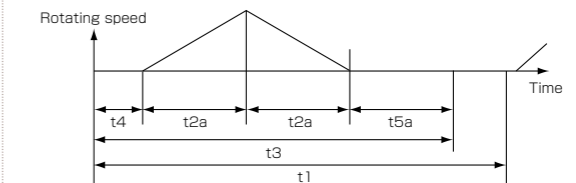

6

Conclusion

○The motor selected at trial selection must meet with following 2 conditions :

If it does not meet these conditions, please re-select the suitable motor or reconsider the required specifications.

Positioning condition $t_3 \leq t_0$

Heat condition(effective rate) $\frac{t_{rms}}{T_m} \leq 70\%$ (Depend on the heat radiation condition, it is possible to use depend even if the it exceeds 70%)

Caution : Due to the rate between the load inertia moment and the rotor inertia of the selected motor and the acceleration and deceleration time, larger regenerative resistor or additional regenerative resistors may be required.

● τ DISC servo motor series torque reference chart

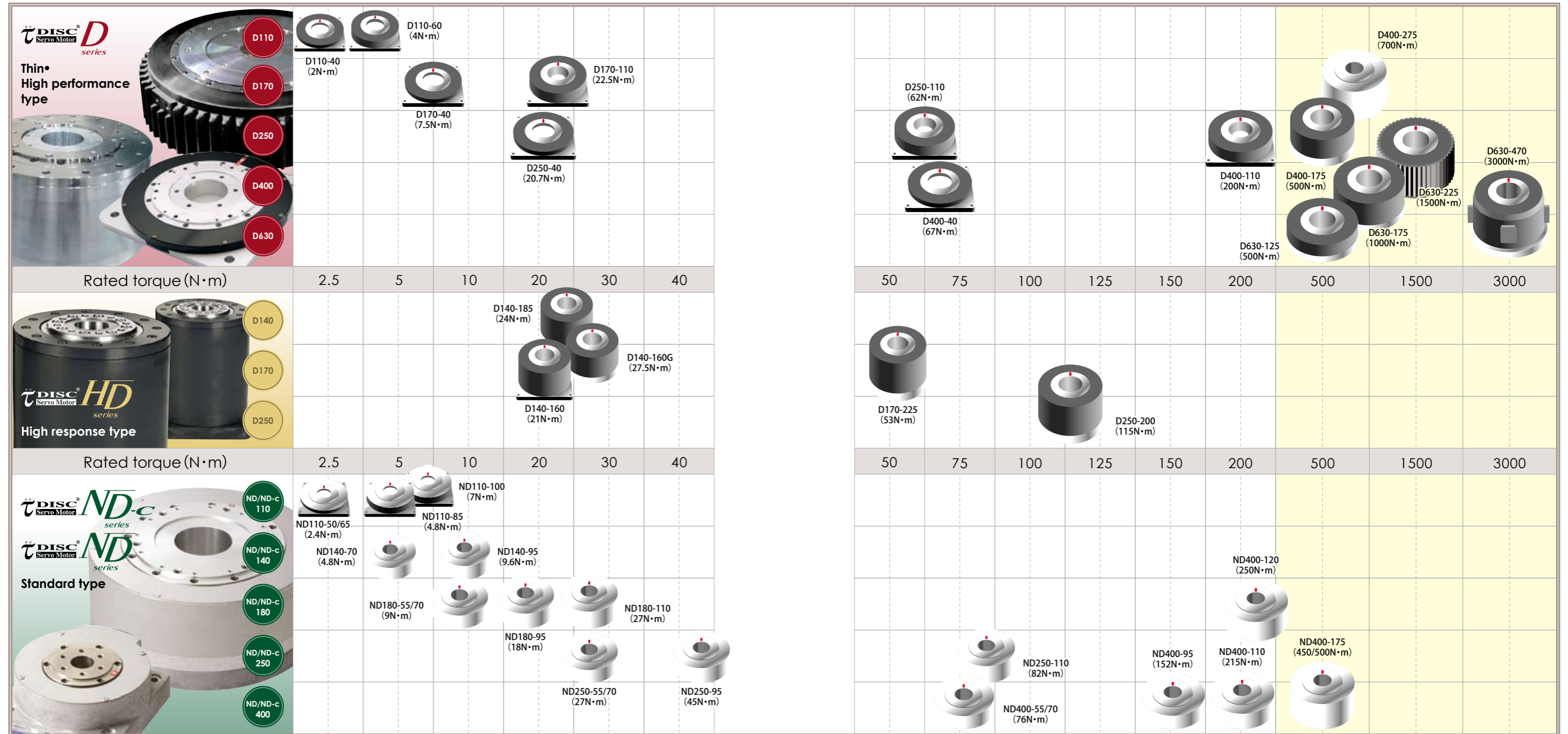

The other product line-ups
Nikki Denso recommends

With Nano level High precision control technology and effective production system, Nikki Denso can provide with a solution for the high accuracy fine processing requirements.



τ iD roll
Hollow type 550~2550N·m
Shaft type 550~3000N·m



τ Linear servo motor
Core-less type 7~1000N
Core type 250~1500N



Servo compass
Moving radius 178mm~1525mm
Arc motion type



AC servo motor
Synchronous type 50W~ 29kW/2000rpm~3000rpm
Induction type 1.2kW~55kW/1000rpm~4000rpm

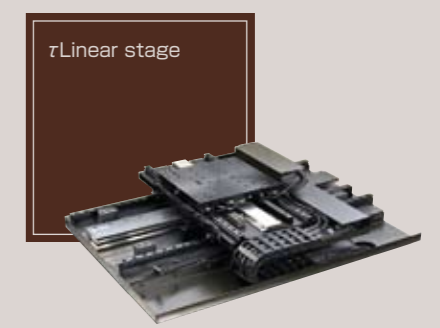

τ Linear stage
X/XY/Xθ/XYθ stage
Corresponding custom-made